

KoldLok[®] SplitLok[™] Square Raised Floor Grommet

Covers Part Number:
5050

The 10-pack carton contains:

- KoldLok[®] Raised Floor Grommets (10)
- Self-Tapping #8 Screws (40)
- Installation Guide (1)

SAFETY REQUIREMENTS

Installers must be familiar with standard safety and risk management practices when working on server rack equipment or in data center environments.



Tools and Preparation

Tools Required:

- Phillips head screwdriver
- Cutting tool (per floor tile manufacturer recommendations)
- Tape measure
- Isopropyl alcohol or equivalent for cleaning

KoldLok[®] SplitLok[™] Square Raised Floor Grommet

Part Number	Inches	Millimeters
5050	7.50" x 7.39" x 1.64"	190.5mm x 187.71 mm x 41.66 mm

Specifications	Inches	Millimeters
Product height above the raised floor	.14"	3.56 mm
Usable cable area	4.5" x 3"	203 mm x 102 mm
Cut required to install Grommet in interior of the tile	5.75" x 5.75"	146 mm x 146 mm
Cut required to install long side of the grommet on the tile edge	6.5" x 5.75"	165.1 mm x 146 mm

For Sales and Installation, contact:



(800) 328-2256 • www.dataclean.com

Preparation:

Cutting Raised Floor Tiles

Each raised floor tile manufacturer provides instructions to properly and safely modify their products. Installers must be familiar with and observe tile manufacturer's recommendations with regard to applicable tools, cutting procedures, the design load capacity of the cut tile, and any additional underfloor support requirements for cut raised floor tiles.

***IMPORTANT:** Data center best practices indicate that tiles should not be cut within the raised floor environment in order to protect equipment from harmful particulates. However, quick clean up of any debris or loose particulates is always recommended. Clean the tile and bottom surface of the grommet using an alcohol wipe or a clean cotton cloth, damp with a solution of at least 50 percent isopropyl alcohol.

HELPFUL TIP: When choosing your cleaning cloth, do not use fabric or paper that will disintegrate or leave particles that could interfere with the adhesive or contribute to airborne contamination.

Installation on the Tile Interior

1. Make a 5.75" x 5.75" cutout (146 mm x 146 mm) in the floor tile. Ensure that any burrs that resulted from cutting the floor tile have been removed. It is not necessary to dress the cutout when installing a KoldLok® SplitLok™ Square Raised Floor Grommet.
2. Test-fit KoldLok® to the floor tile by making the flange flush with the topside of the floor tile. Ensure there is no binding and that the fit is even on the Grommet.
3. With the Grommet properly placed in the floor tile, fasten it securely to the floor tile using the self-tapping screws. Do not over-torque the screws.

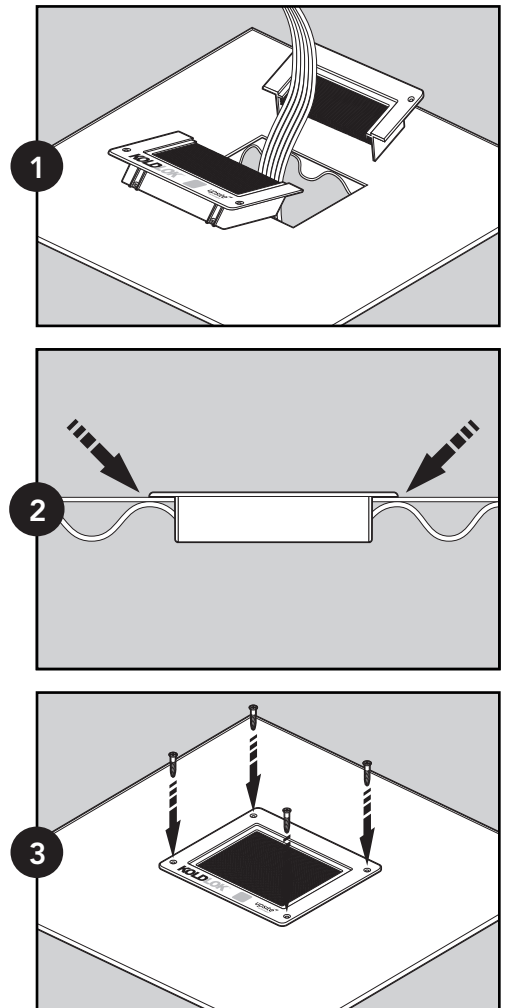

For Sales and Installation, contact:



(800) 328-2256 • www.dataclean.com

Installation on the Tile Edge

1. Provide a 6.5" x 5.75" cutout (165.1 mm x 146 mm) in the floor tile. Ensure that any burrs that resulted from cutting the floor tile have been removed. It is not necessary to dress the cutout when installing a KoldLok® SplitLok™ Square Raised Floor Grommet.
2. Test-fit KoldLok® to the floor tile, with flange on the topside of the floor tile. Ensure there is no binding and that the fit is even on the Grommet.
3. With the Grommet properly placed in the floor tile, fasten it securely to the floor tile using the self-tapping screws. Do not over-torque the screws.

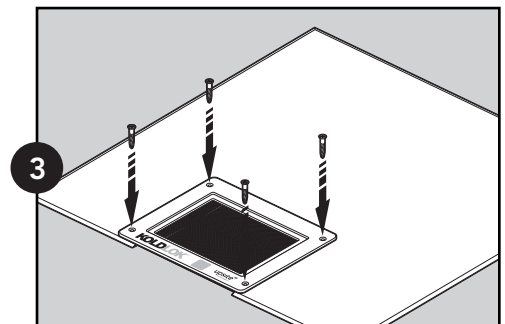
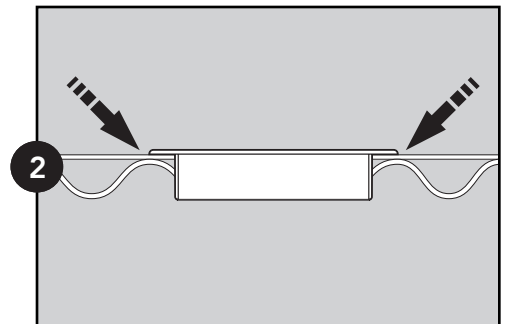
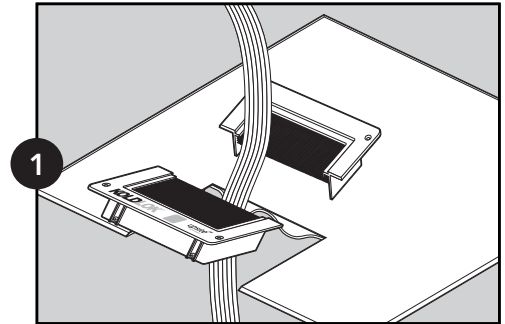

General Information

Effective Installation of Cables

In order to minimize any air loss from under the raised-floor plenum, allow for adequate slack in the cables. If the cables are under too much tension, the grommet filaments may be pulled apart, resulting in a V-shaped gap that will cause an increase in the volume of air escaping from under the raised floor.

Maintaining Proper Cooling of Equipment

Failure to follow computer manufacturer's guidelines for maintaining proper cooling may result in the overheating of equipment. Ensure that there is adequate airflow to the intake side of the computer equipment or cabinets through devices such as perforated floor tiles or grates. Achieving proper airflow to the intake side of computer equipment and/or cabinets is the responsibility of the customer.

Customer Support

If you have any questions, please contact us direct at 505.798.0200 or Toll Free at 888.982.7800
Email us at info@upsite.com

For Sales and Installation, contact:



(800) 328-2256 • www.dataclean.com

Installation Guide

Limited Warranty

Upsite Technologies, Inc. (the *Company*) warrants to the original purchaser that products delivered hereunder will be free of defects in materials and workmanship for a period of twelve (12) months from the date of purchase (the "Warranty Period").

The *Company* shall, at its option, within the Warranty Period, either repair or replace free of charge, any product or part thereof found, upon the *Company's* inspection, to be defective in materials and workmanship, and will return the repaired or replaced product to the purchaser at *Company's* expense.

For warranty service and shipping instructions, contact the *Company* at the telephone number shown below. If the product is under warranty and the defect appears to be covered by this Limited Warranty, the *Company* will issue to the purchaser a Notice of Authorization For Warranty Return. Products returned to the *Company* for warranty service must be accompanied by a statement of defect, the Notice of Authorization for Warranty Return provided by the *Company*, and proof of purchase.

This Limited Warranty is conditioned on the following:

1. The *Company* must be notified within 12 months of purchase and have been given the opportunity of inspection by return of any alleged defective product free and clear of all liens and encumbrances to the *Company* or its manufacturer; and
2. The product must not have been abused, misused, or improperly maintained, and/or non-Upsite authorized repair performed during such period; and
3. Such defect has not been caused by corrosion or exposure to other than ordinary wear and tear; and
4. The installation and use of the product has been in accordance with the manufacturer's instructions and not been modified or customized to include but not limited to cut, resized, burned, glued, bent, re-shaped, disassembled, attachments added to, improperly installed or used in a manner other than intended.

The company makes no other express or implied warranty or representation of any kind whatsoever including any warranty of merchantability or fitness for a particular purpose and all such other warranties are hereby included.

The *Company's* maximum liability hereunder is limited to the purchase price of the product. In no event shall the *Company* be liable for any consequential, indirect, incidental, or special damages of any nature arising from the sale or use of the product, whether based in contract, tort, strict liability, or otherwise.

Note: Some jurisdictions do not allow limitations on incidental or consequential damages or how long an implied warranty lasts, so that the above limitations may not fully apply. This warranty gives specific legal rights and you may also have other rights which may vary from jurisdiction to jurisdiction.

For complete warranty and repair information Call 888.982.7800 or visit upsite.com

U.S. and International Patents Pending.



Designer and Manufacturer
888.982.7800
www.upsite.com

For Sales and Installation, contact:



(800) 328-2256 • www.dataclean.com