

For Sales and Installation, contact:



(800) 328-2256 • www.dataclean.com



SLIDING DOORS

AISLELOK[®]

INSTALLATION GUIDE

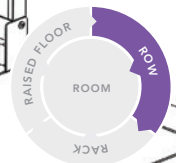

BEFORE YOU BEGIN

We recommend that you familiarize yourself with the contents of this installation guide before beginning the installation process. Doing so will save you a lot of time and effort. Including a review of this guide, it shouldn't take longer than ten minutes to set up the Upsite Technologies Sliding Doors.

The bulk of this document covers tool-less installation on IT cabinets, but there are also sections on mechanical attachment as well as set up using one of our Adjustable Mounting Posts.

Installation Tips are on page 23 and a Trouble Shooting guide is on page 24 at the end of this document.

For Sales and Installation, contact:



(800) 328-2256 • www.dataclean.com

INCLUDED PARTS (SLIDING DOORS)

VERTICAL POSTS

- A. Vertical Post A | x1
- B. Vertical Post B | x1

HEADER ASSEMBLY

- C. Header Assembly | x1

DOOR PANELS

- D. Door Panel Left | x1
- E. Door Panel Right | x1

ANTI-SHEAR PLATE KIT

- F. Anti-Shear Plates | x4
- G. Thumb Screws | x8

END CAP KIT

- H. Header End Cap Left | x1
- I. Header End Cap Right | x1
- G. Thumb Screws | x2

TETHER KIT

- J. Tether Cable | x2

DOOR ATTACHMENT KIT

- K. Header Knob | x4
- L. Sliding Door Shims | x12

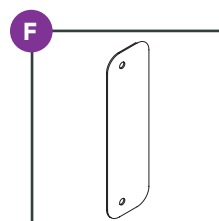
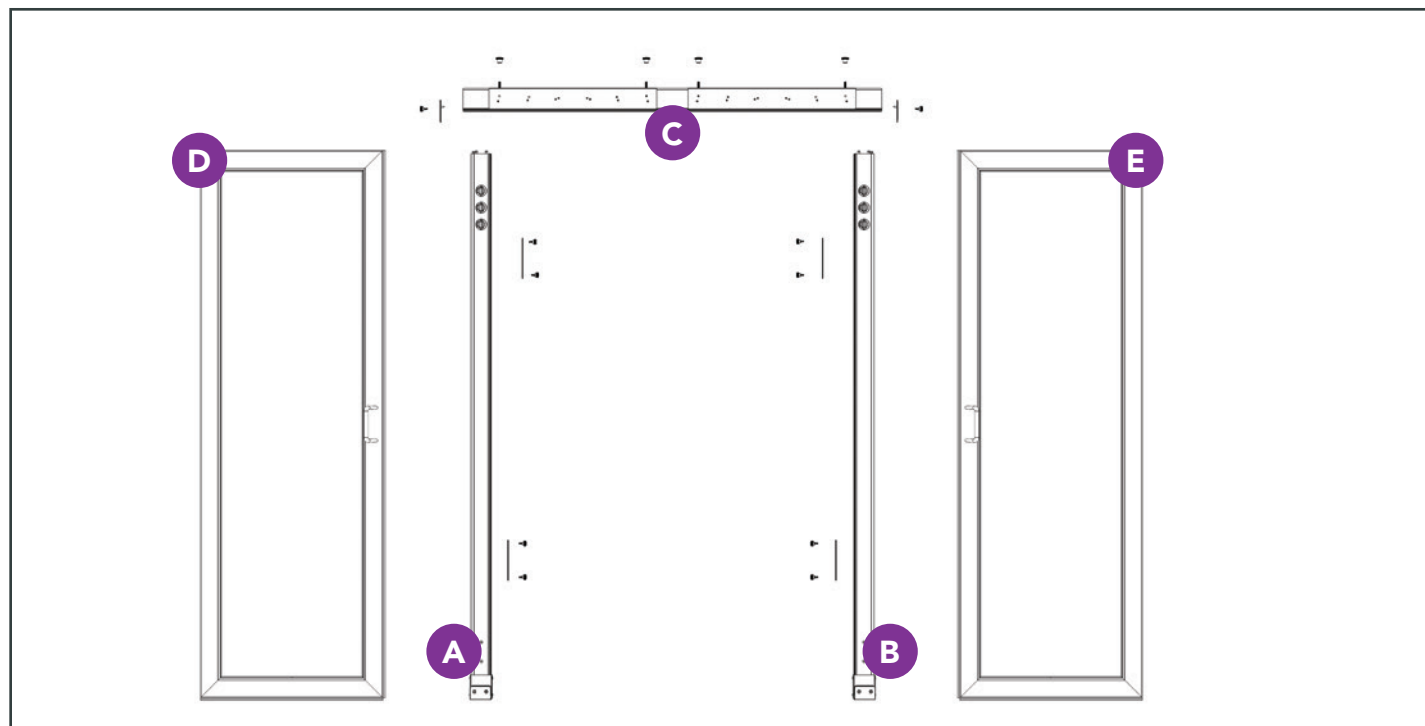

x4

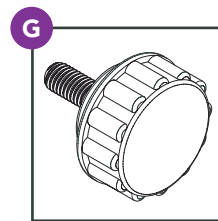

x10

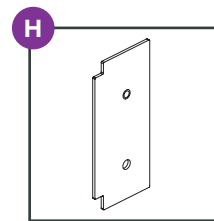

x1

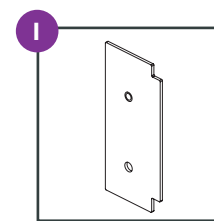

x1

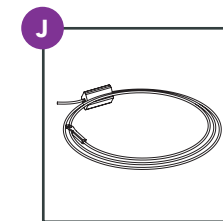

x2

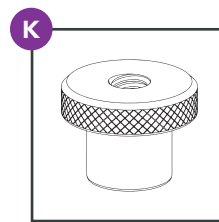

x6

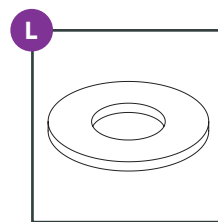

x12

Note: No Tools Required

For Sales and Installation, contact:

 (800) 328-2256 • www.dataclean.com

VERTICAL POST PLACEMENTS

4 - 4'6" Aisle

4' Door

For an aisle width of 4' - 4'6": Vertical Post A will be on the left side, and Vertical Post B will be on the right side of the aisle.

6 - 6'6" Aisle

6' Door

For an aisle width of 6' - 6'6": Vertical Post A will be on the left side, and Vertical Post B will be on the right side of the aisle.

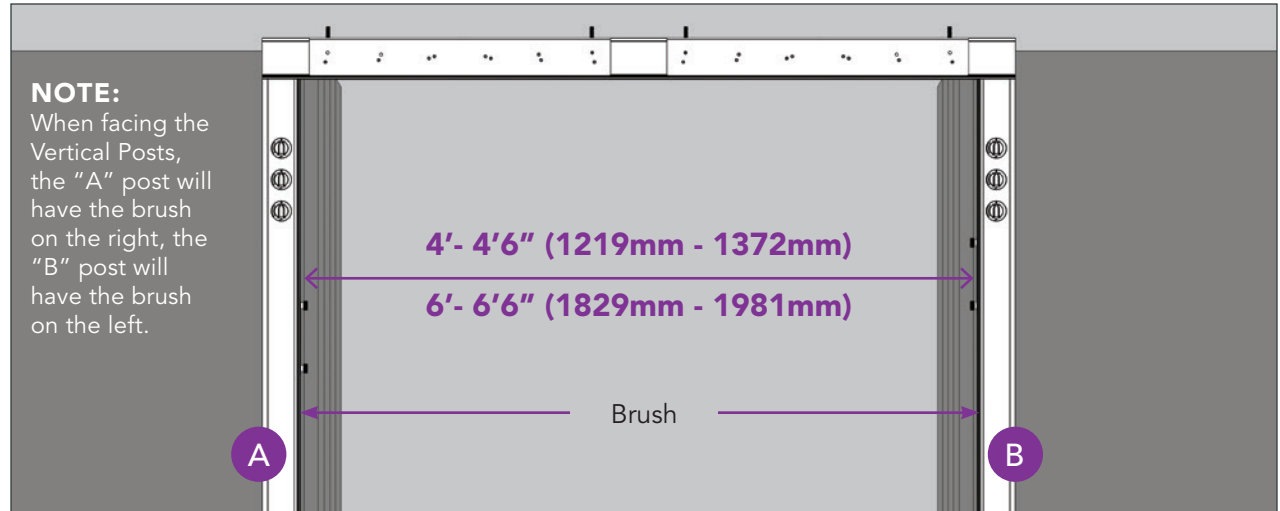

Note: Aisle width is distance between face of cabinet frames

3'10" - 4' Aisle

4' Door

For an aisle width of 3'10" - 4': Vertical Post A will be on the right side, and Vertical Post B will be on the left side of the aisle.

5'10" - 6' Aisle

6' Door

For an aisle width of 5'10" - 6': Vertical Post A will be on the right side, and Vertical Post B will be on the left side of the aisle.

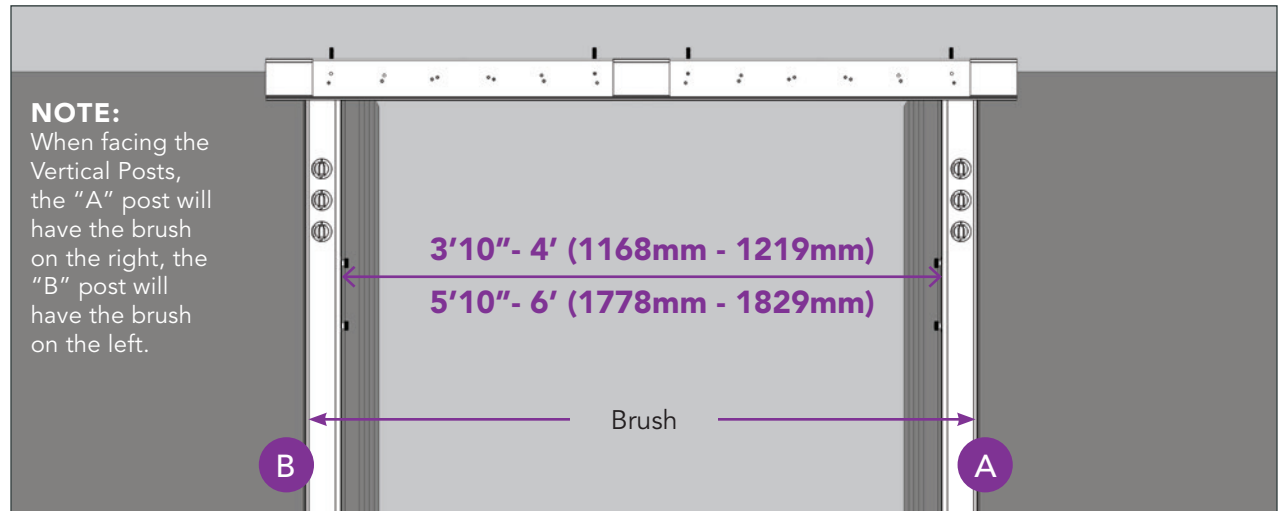

Note: Aisle width is distance between face of cabinet frames

For Sales and Installation, contact:



(800) 328-2256 • www.dataclean.com

STEP 1

Attach the Vertical Posts to the cabinets.

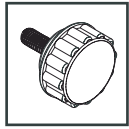

x8

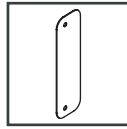

x4

PREPARATION: Please refer to the Vertical Post placement guide on the previous page to determine the placement and orientation of the Vertical Posts.

NOTE: Please refer to Mechanical Installation on page 19 for instructions on how to mechanically fasten vertical posts to cabinets.

1.1 - Slightly angle the Vertical Post and place the bottom of the post up against the bottom edge of the cabinet frame. Pivot the Vertical Post up against the side of the cabinet. (Figure 1) Align Vertical Post with the front edge of the cabinet frame.

1.2 - Lock each of the magnets on top of the Vertical Post by turning the knobs clockwise to the lock position. (Figure 2)

1.3 - Attach the Anti-Shear Plates to the side of the Vertical Post. Anti-Shear Plates should align with the front edge of the cabinet frame, between the frame and the rack door. (Figure 3)

1.4 - Repeat the same process for the remaining Vertical Post.

For Sales and Installation, contact:



(800) 328-2256 • www.dataclean.com

Fig.1

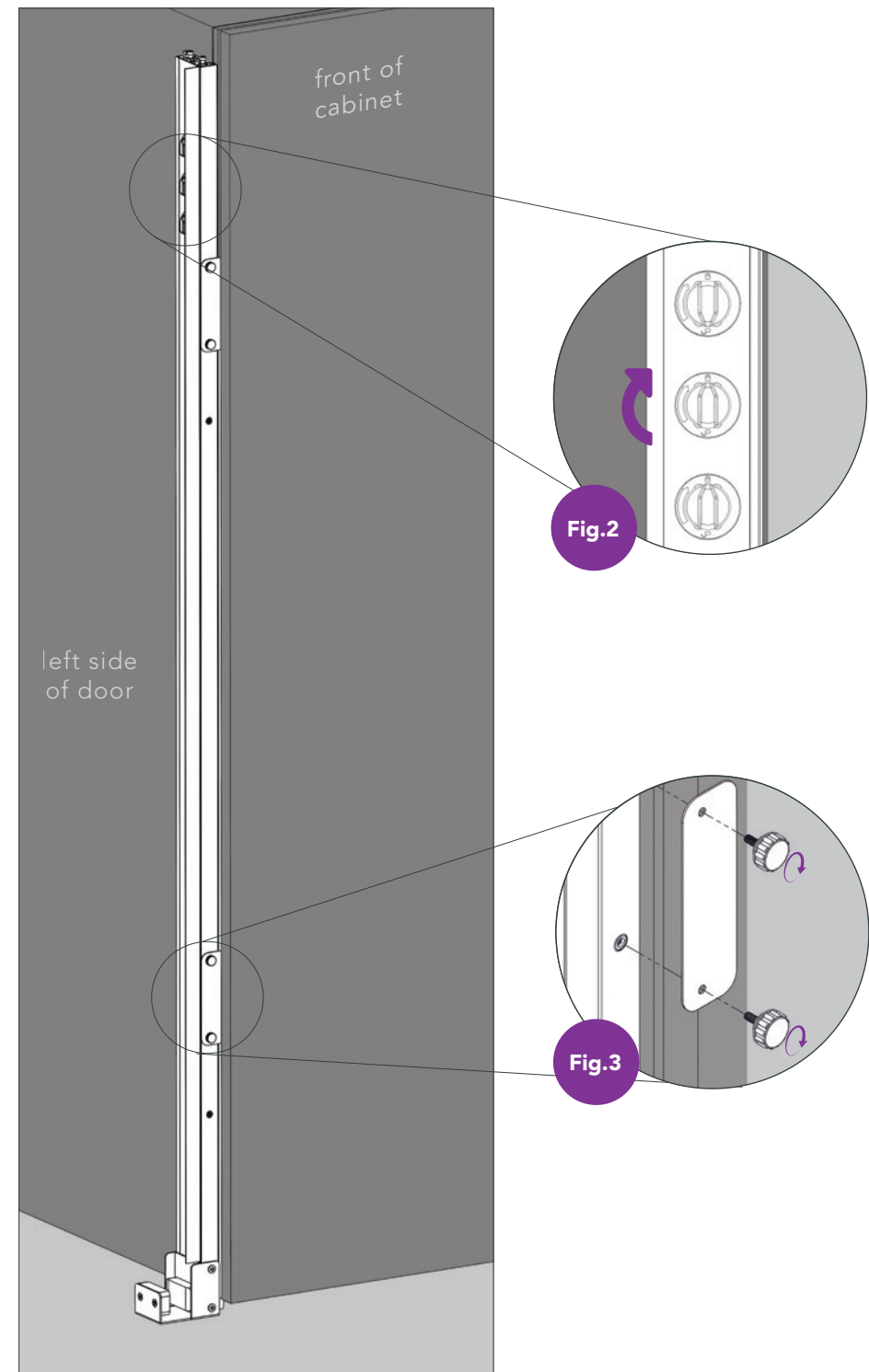
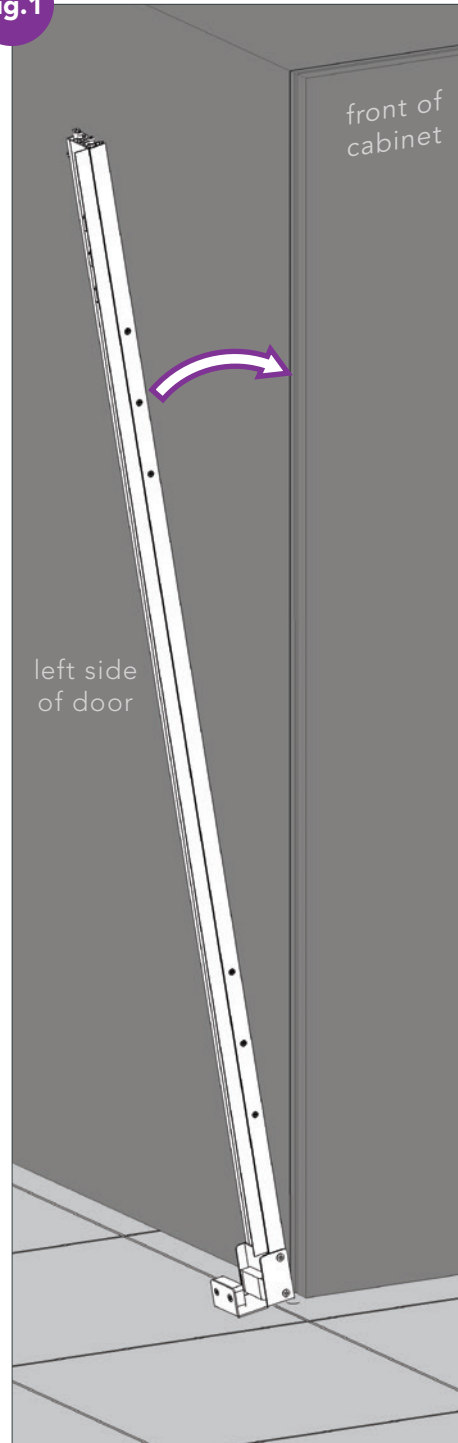

STEP 2

Attach Header Assembly to the top of the Vertical Posts.

2.1 - Hold the Header Assembly on top of the posts with the t-slot facing down and the slides facing away from the racks. Position the Header Assembly so one end rests on the inside edge of a post and the other end rests on top of the pins in the opposite post. (Figure 1)

Fig.1

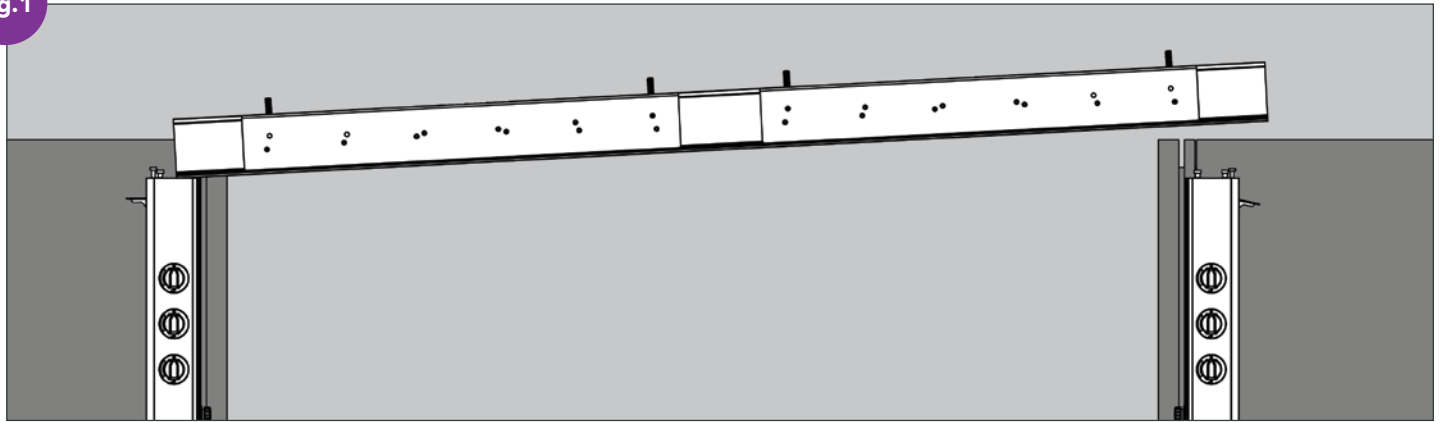

2.2 - Slide the Header Assembly so the locating pins and the latch pin slide into the t-slot, and the other end of the Header Assembly is just past the pins in the opposite post. (Figure 2)

Fig.2

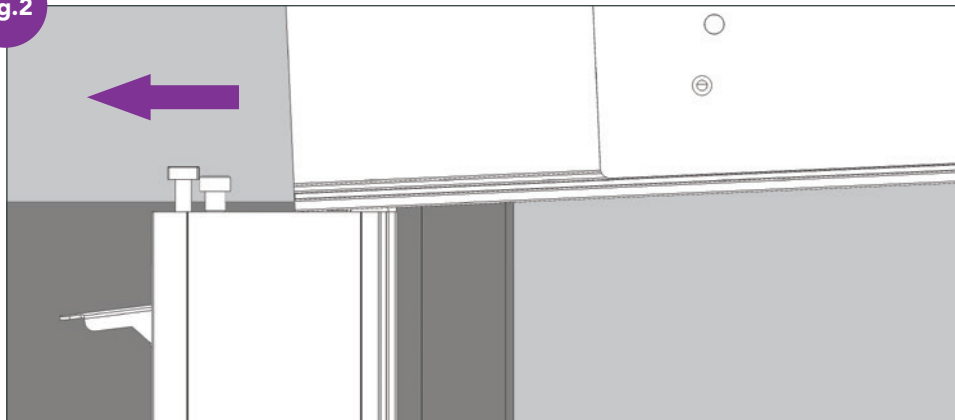

2.3 - Slide the Header Assembly in the opposite direction so the locating pins and the latch pin slide into the t-slot of the Header Assembly and the Header Assembly is centered on the Vertical Posts. (Figure 3 & 4)

Fig.3

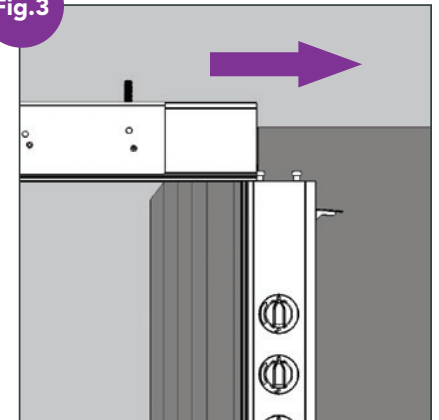

2.4 - Lock the Header Assembly to the Vertical Post(s) by pulling down on the Vertical Post latch. (Figure 5)

Fig.4

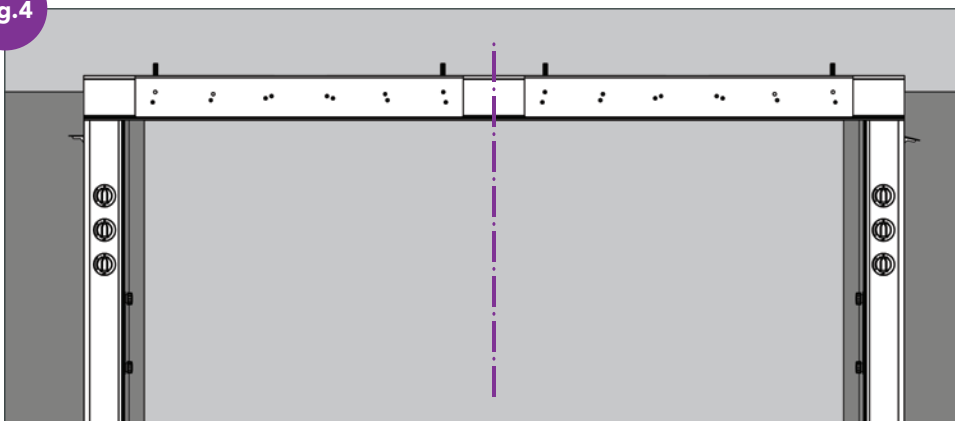
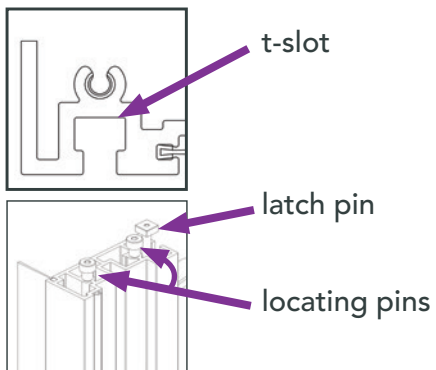
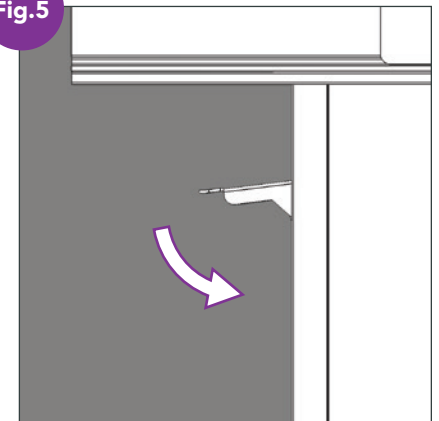

Fig.5



STEP 3

Install the Header End Caps and Tether Cables.

STOP! Installing the Transom Window?

Please refer to the Transom Window Install Guide on page 11 at this point if you are installing a Transom Window.

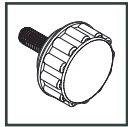

x2

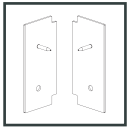

Left x1
Right x1



x2

3.1 - Place Header End Caps on the end of the Header Assembly with the guide pin fitting into top boss on the end of the Header Assembly. (Figure 1)

3.2 - Place the Thumb Screw through the eyelet at the end of the Tether cable, then partially thread the Thumb Screw through the Header End Cap and into the end of the Header Assembly. *Do not fully tighten the Thumb Screw at this point. (Figure 2)

3.3 - Pull the end of the Tether Cable over the top of the cabinet and loop through a secure location. (Figure 3)

Step Three continued on the next page.

For Sales and Installation, contact:



(800) 328-2256 • www.dataclean.com

Fig.1

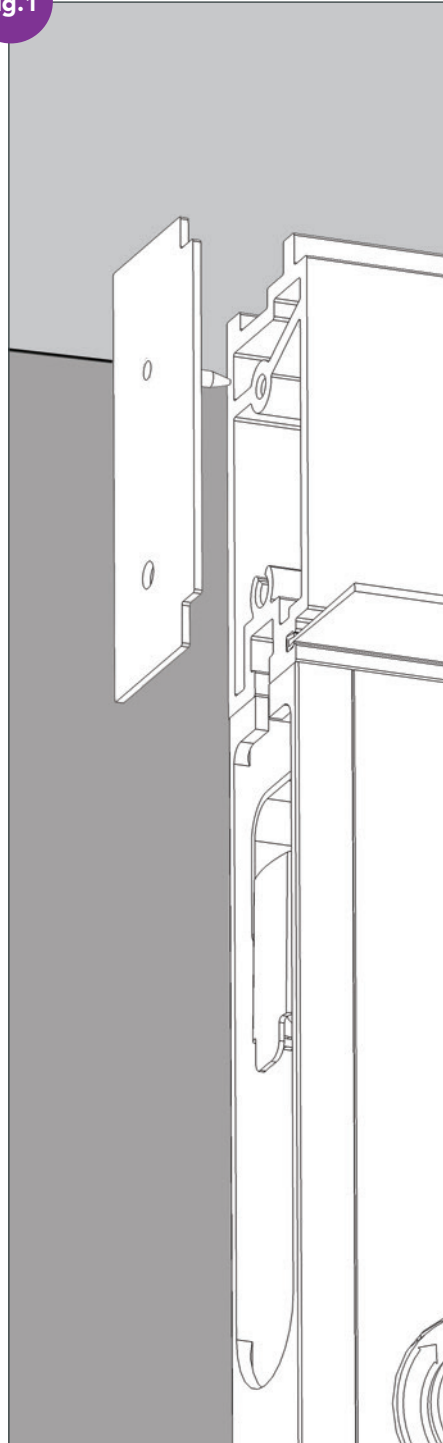

Fig.2

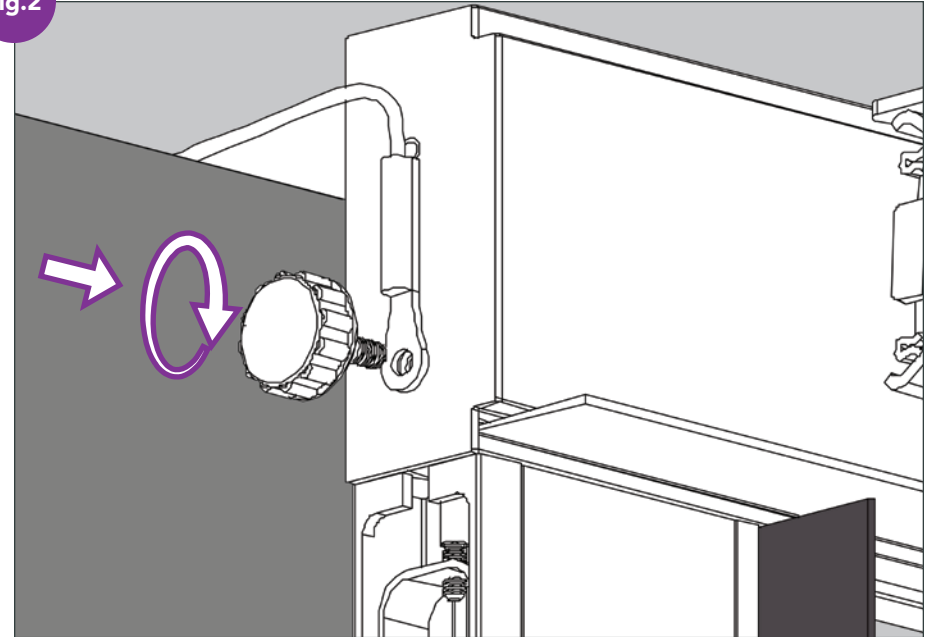
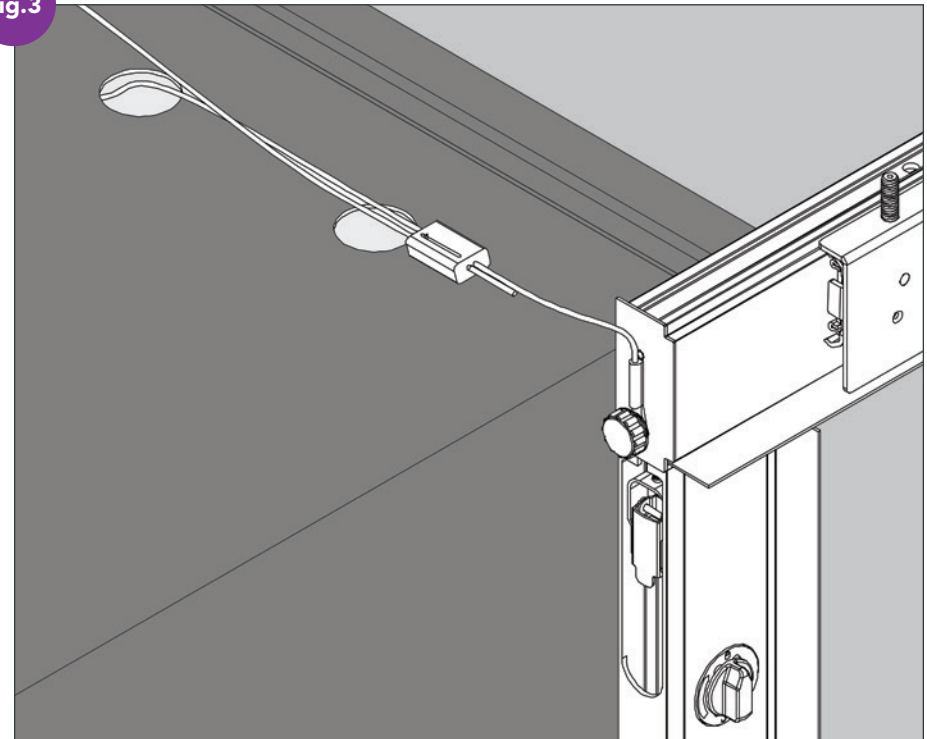

Fig.3



STEP 3 (cont.)

Install the Header End Caps and Tethers.

3.4 - Once the Tether Cable is looped through a secure location, push the end of the Tether Cable through the cable lock in the opposite direction, and pull tightly to remove all slack. (Figure 4)

3.5 - Tighten the Thumb Screw to secure the Tether Cable and Header End Cap to the Transom Window. (Figure 5)

3.6 - Repeat on the opposite end of the Header Assembly.

Fig.4

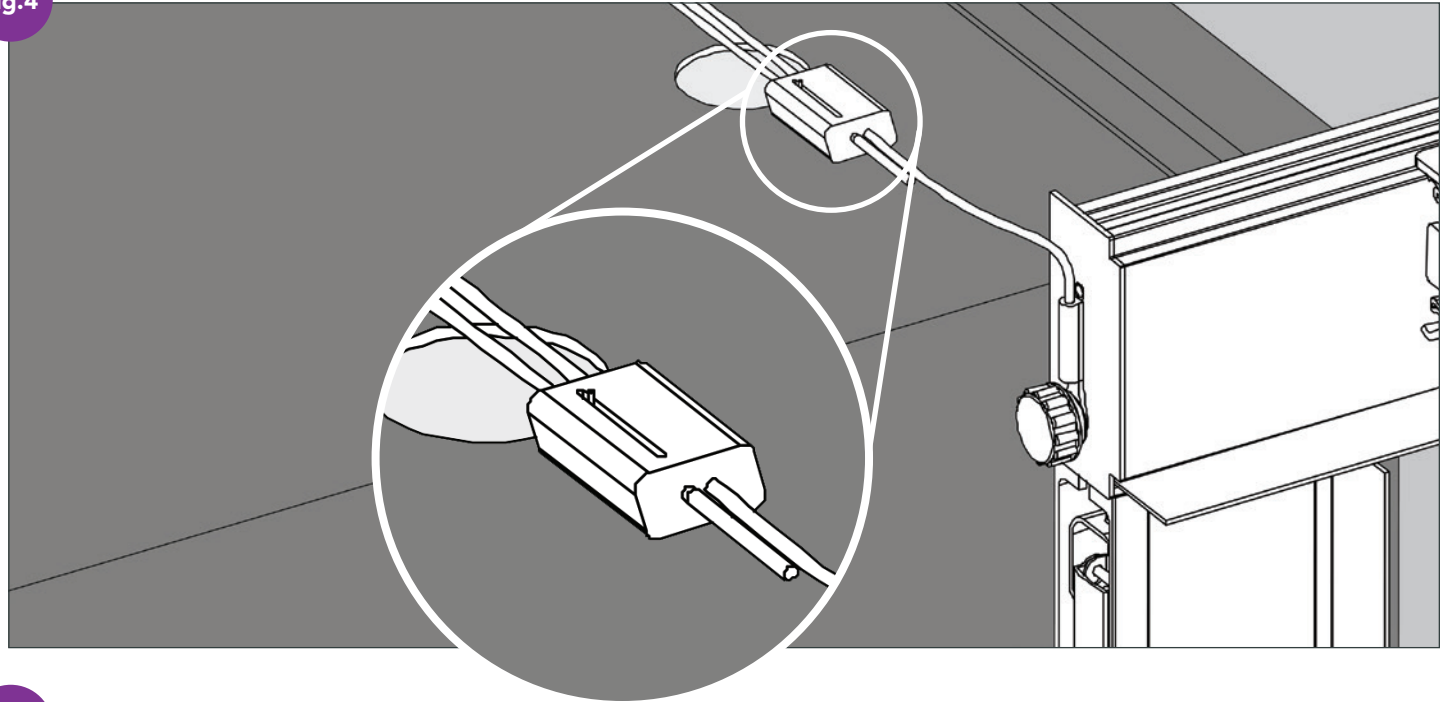
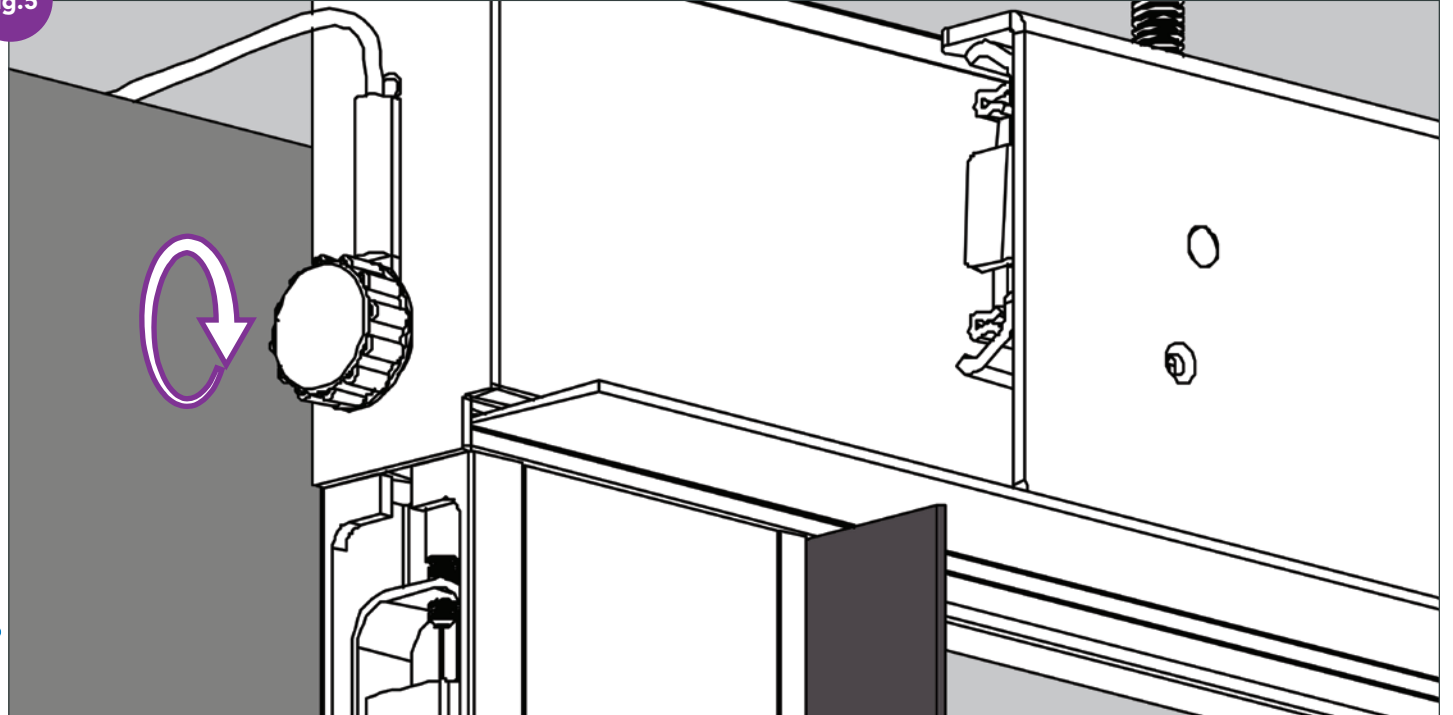

Fig.5



For Sales and Installation, contact:

Data Clean[®]

(800) 328-2256 • www.dataclean.com

STEP 4

Hang Door Panels on Header Assembly



4.1 - Align the bottom of the door inside the guide channel. (Figure 1)

4.2 - Align the Door Panel cleat with the slider studs on the Header Assembly. (Figure 2)

4.3 - Place the Door Panel cleat on top of the slider studs and make sure the bottom of the Door Panel lands inside the guide channel. (Figure 3)

4.4 - Check the seam where the Door Panels meet. If the Door Panels are not parallel then lift the Door Panel and place Sliding Door Shims on the slider studs under the door cleat to fine tune the Sliding Door Panel alignment. (Figure 4)

SLIDING DOOR SHIM PLACEMENT

Fig.4

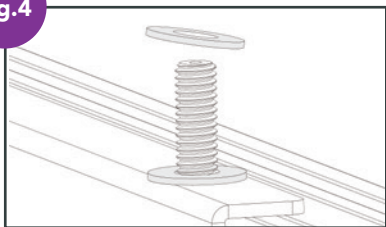

Step Four continued on the next page.

Fig.1

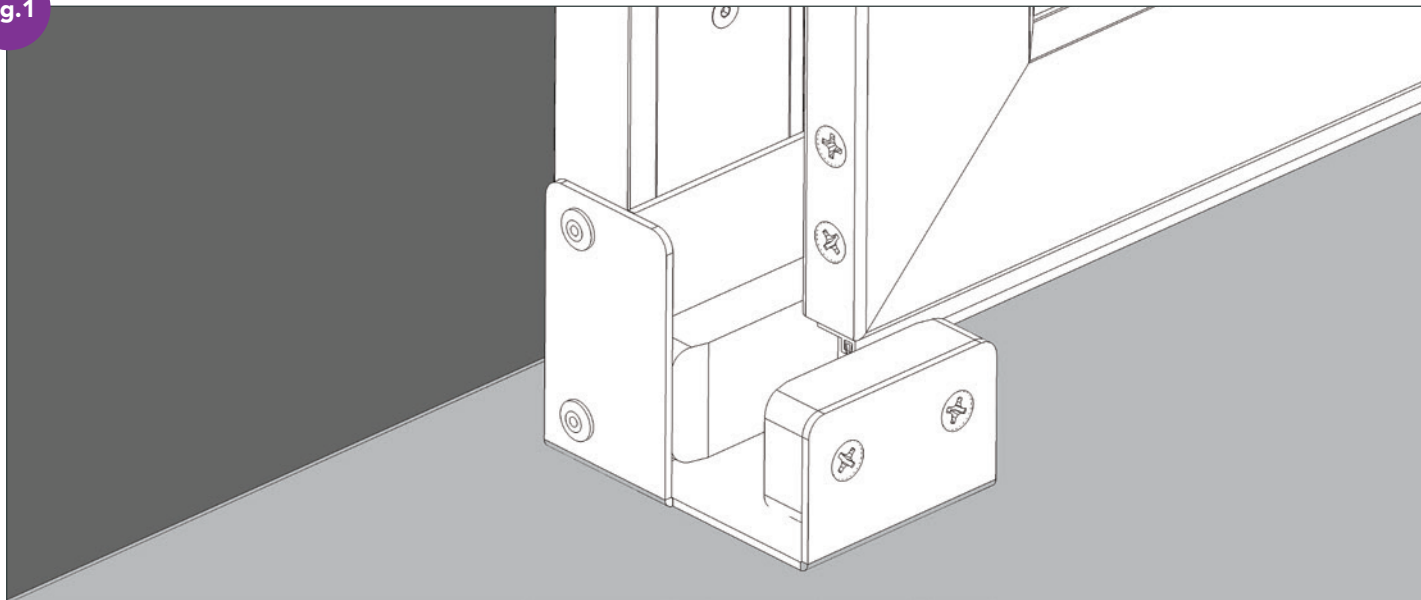

Fig.2

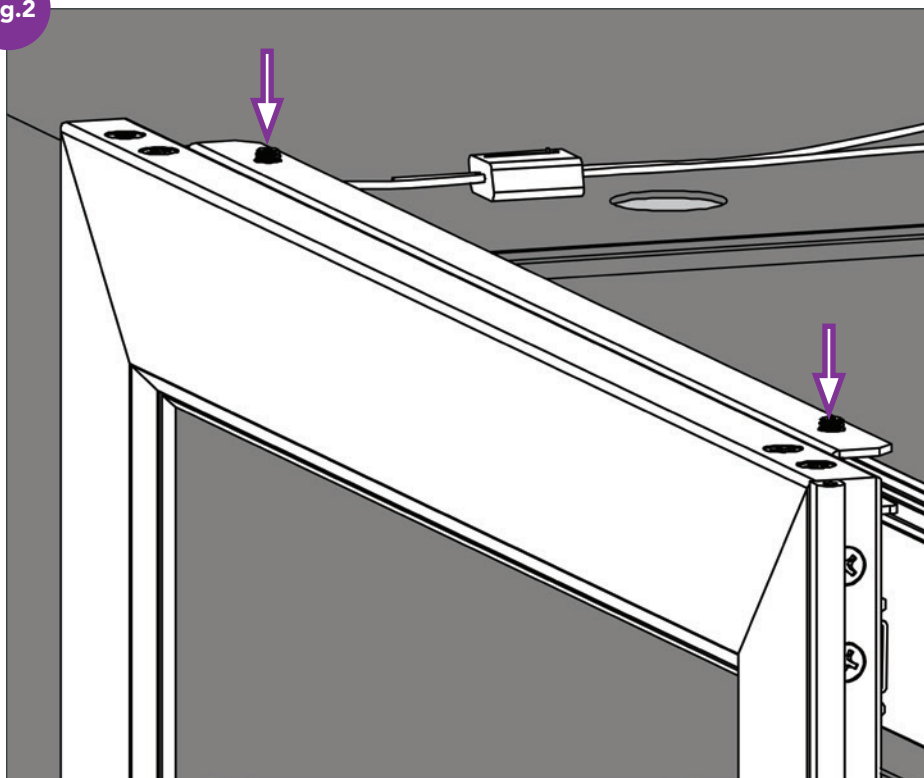
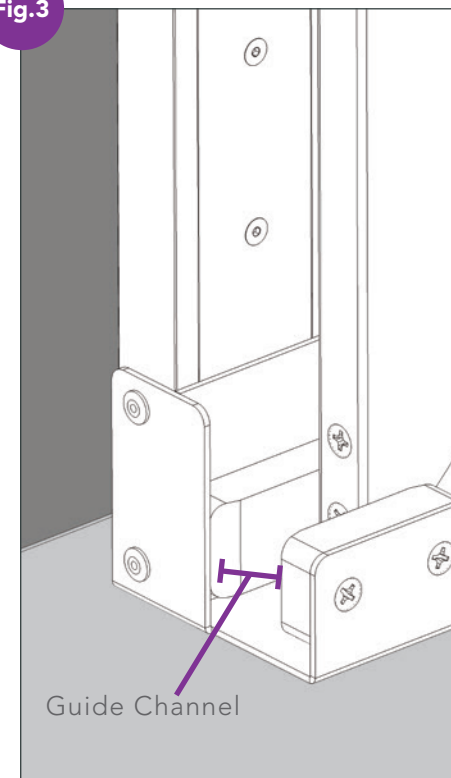

Fig.3



STEP 4

Hang Door Panels on Header Assembly

4.5 - Use the Thumb Screws to secure the Door Panel to the slider. (Figure 5)

4.6 - Repeat for the opposite door.

Fig.5

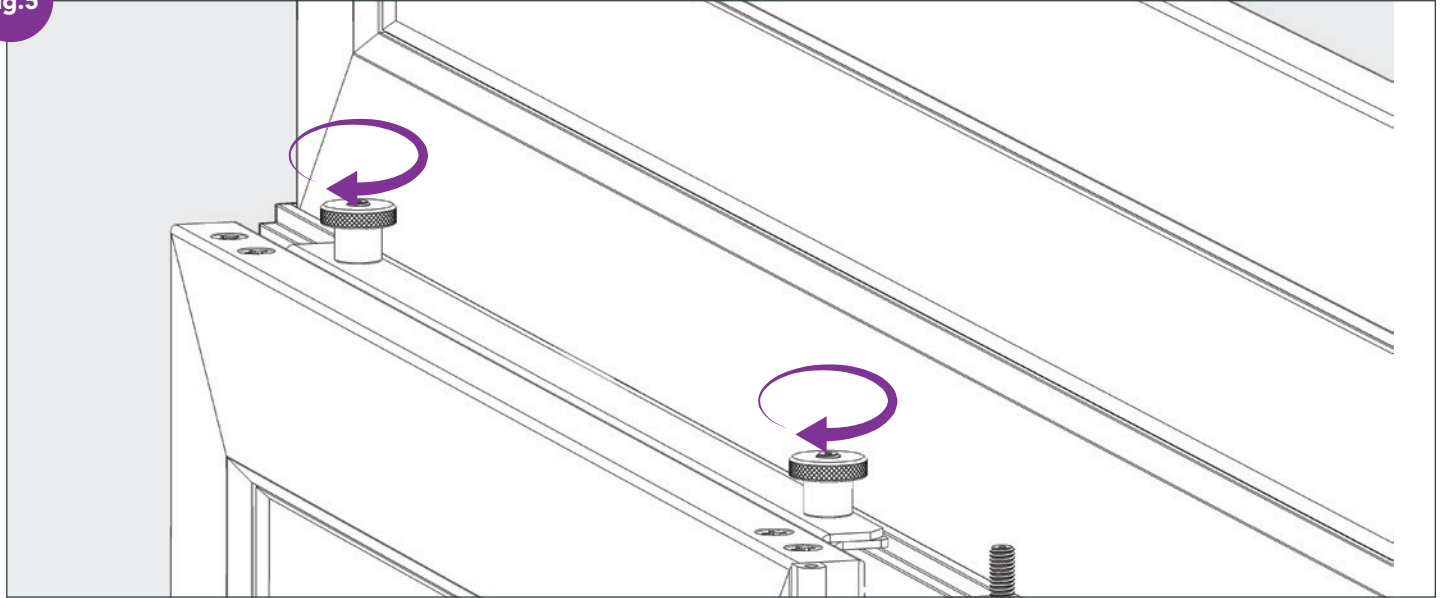

For Sales and Installation, contact:

Data Clean[®]

(800) 328-2256 • www.dataclean.com

For Sales and Installation, contact:



(800) 328-2256 • www.dataclean.com



SLIDING DOORS

AISLELOK[®]

TRANSOM WINDOW INSTALLATION

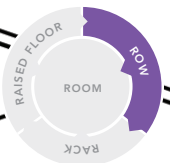

INCLUDED PARTS (TRANSOM WINDOW)

TRANSOM WINDOW

A. Transom Window

x1

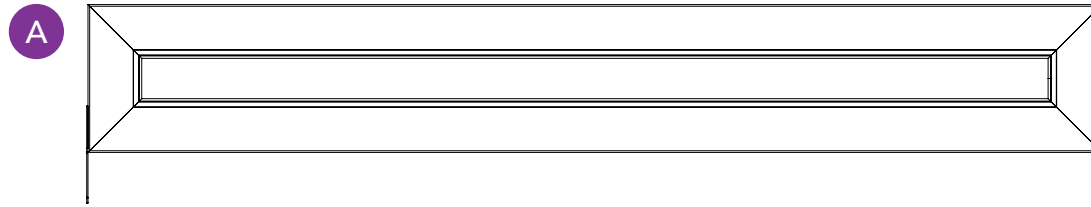

Note: No Tools Required

For Sales and Installation, contact:



(800) 328-2256 • www.dataclean.com

TRANSOM WINDOW INSTALLATION

Installation of the Transom Window

PREPARATION: If the Transom Window is being installed at the same time as the Sliding Door, skip Step 1 below.

NOTE: Make sure not to set the Transom Window on End Caps to prevent bending them.

NOTE: Always remove the Transom Window when relocating the doors.

TW.1 - Remove Thumb Screws, Tether Cables, and Header End Caps on previously installed Sliding Doors. The Header End Caps that came with the doors will not be used. (Figure 1)

TW.2 - Place Transom Window on top of header with the attached Transom End Caps sliding over both ends of the Header Assembly. (Figure 2)

TW.3 - Place a Thumb Screw through the eyelet at the end of a Tether Cable, and then partially thread the Thumb Screw through the Transom End Cap (attached to the Transom Window) and into the end of the Header Assembly. Note: Do not fully tighten the Thumb Screw at this point. (Figure 3)

Fig.1

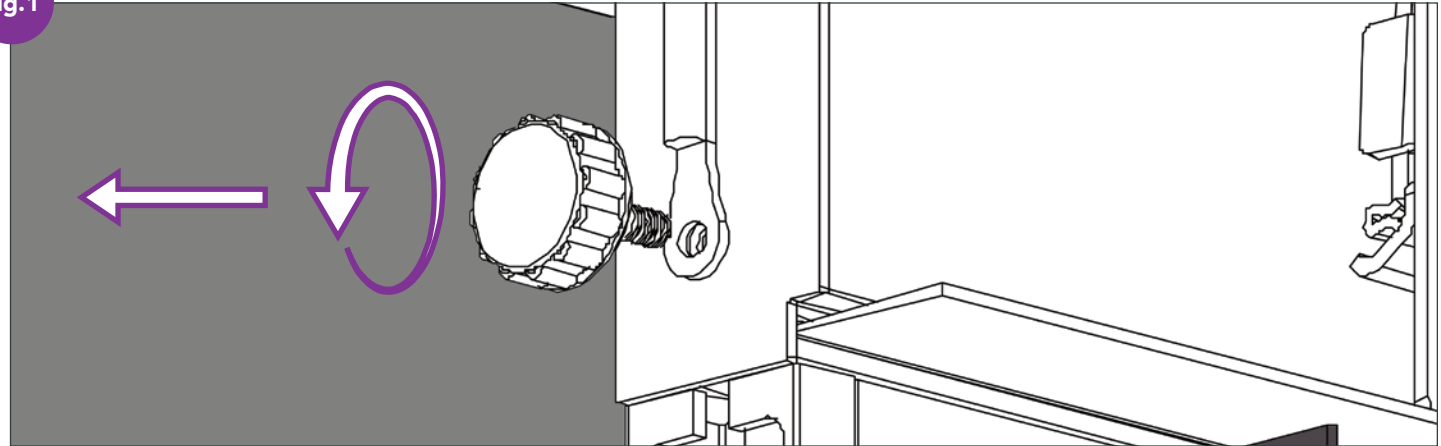

Fig.2

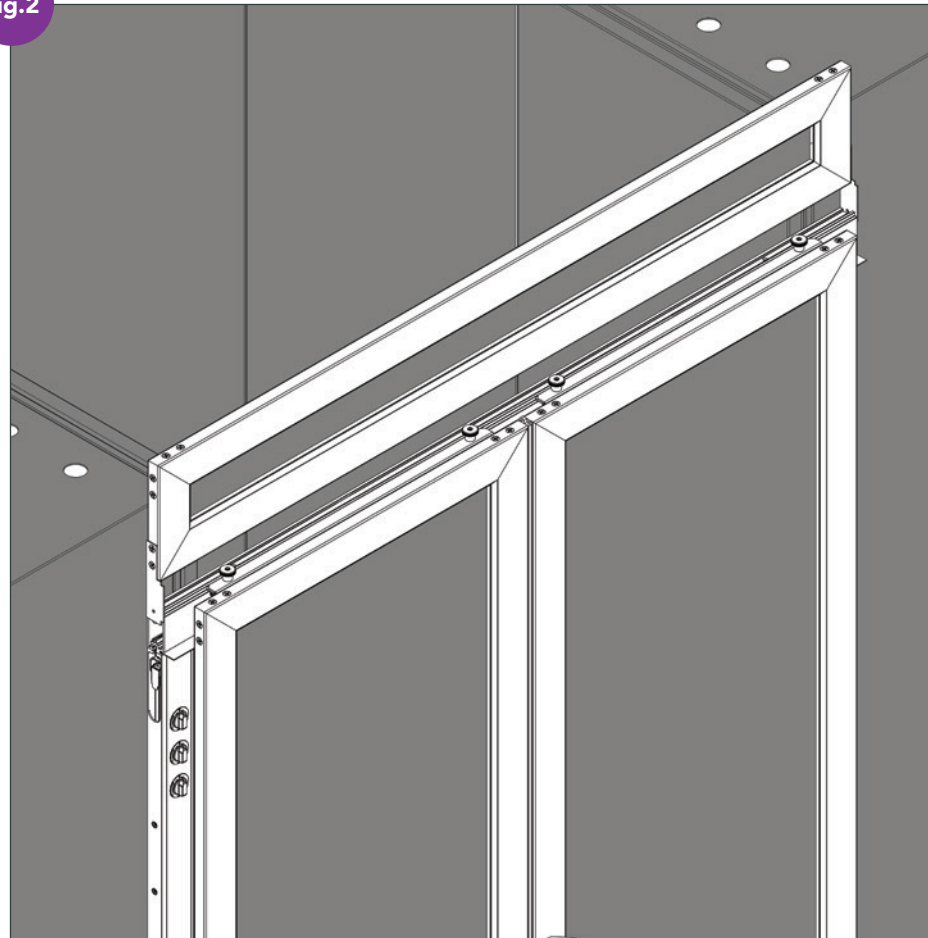
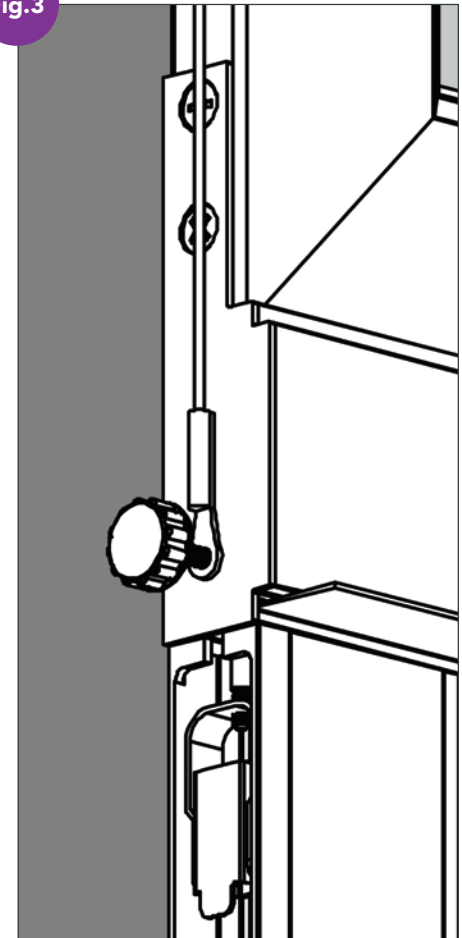

Fig.3



TRANSOM WINDOW INSTALLATION

Installation of the Transom Window

TW.4 - Pull the end of the Tether Cable over the top of the cabinet and loop through a secure location. Once the Tether Cable is looped through a secure location, push the end of the cable through the Tether Cable Lock in the opposite direction, and pull tightly to remove all slack. (Figure 4)

TW.5 - Tighten the Thumb Screw to secure the Tether Cable and End Cap. (Figure 5)

TW.6 - Repeat on the opposite end of the Transom Window to secure the Transom Window to the Header Assembly.

Please go to Step 4 on page 9 to continue Sliding Door Installation.

Fig.4

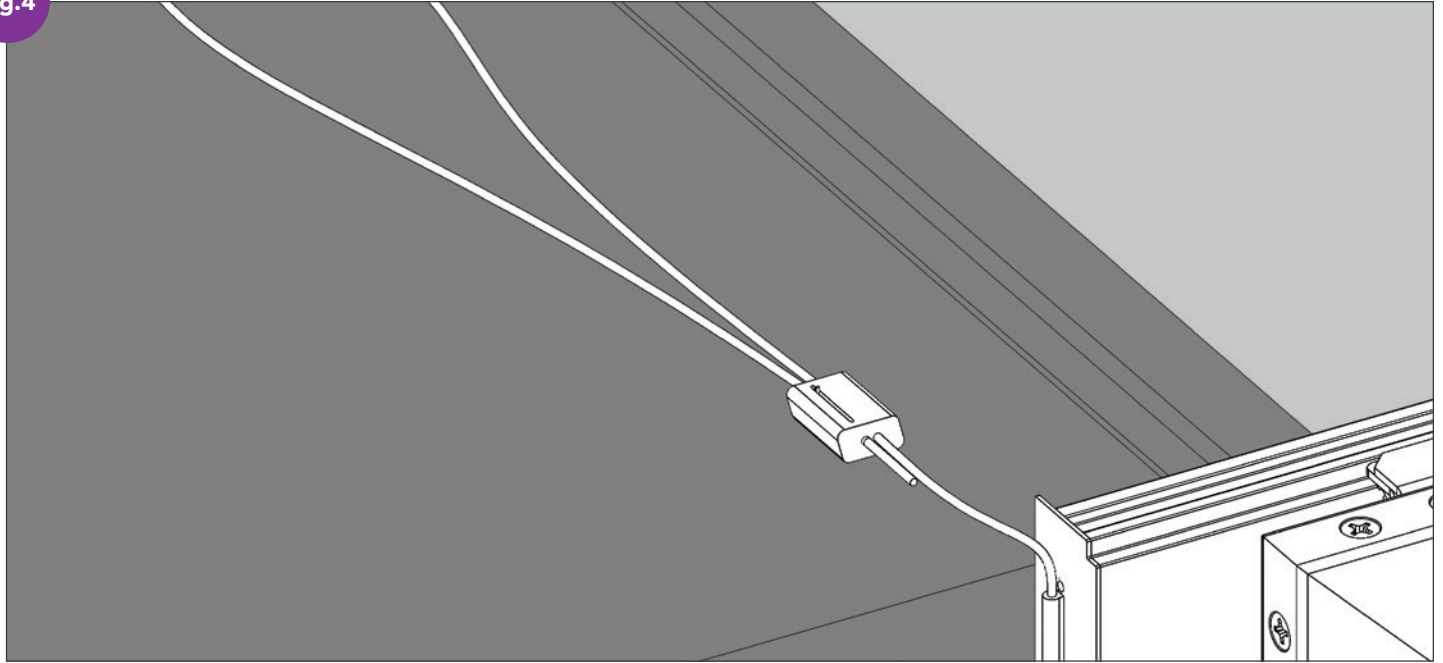
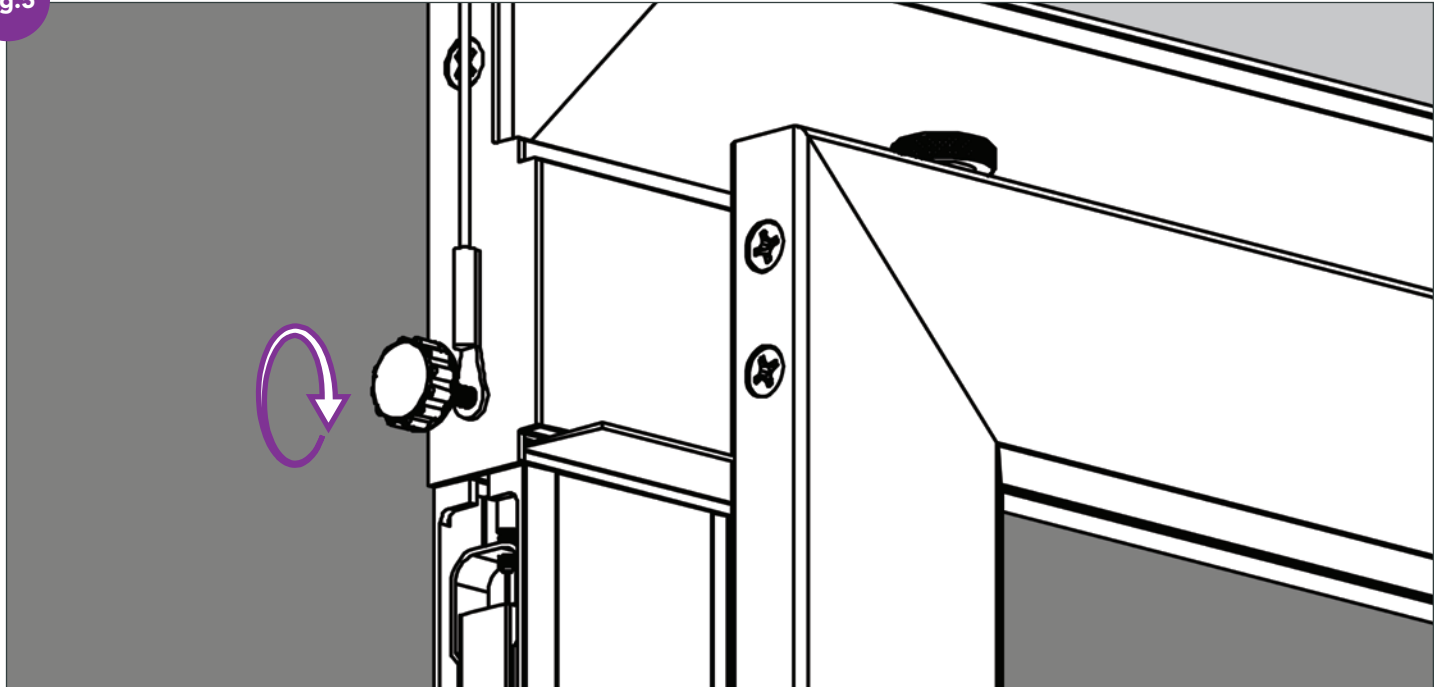

Fig.5



For Sales and Installation, contact:



(800) 328-2256 • www.dataclean.com

SLIDING DOORS

AISLELOK[®]

ADJUSTABLE MOUNTING POST INSTALLATION

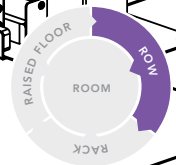

OPTIONAL PARTS (ADJUSTABLE MOUNTING POSTS)

NOTE: The Adjustable Mounting Post is sold separately. Contact your sales representative or see our website for more information.

ADJUSTABLE MOUNTING POST

- A. Adjustable Mounting Post, Top x1
- B. Adjustable Mounting Post, Bottom x1

POST ASSEMBLY HARDWARE

- C. 3/8" Flanged Hex Head Screws x2

FLOOR MOUNTING KIT

- D. 1-5/8"W x 13/16"H x 30"L Unistruts x2
- E. 3/8" Carriage Bolts x4
- F. 3/8" Flat Washers x4
- G. 3/8" Lock Nuts x4

NOTE: The Top Hinge Baseplate Retrofit Kit is not needed with installation of the Sliding Doors

TOP HINGE BASEPLATE RETROFIT KIT

- H. Adjustable Mounting Post, Top x1
- I. Adjustable Mounting Post, Bottom x1

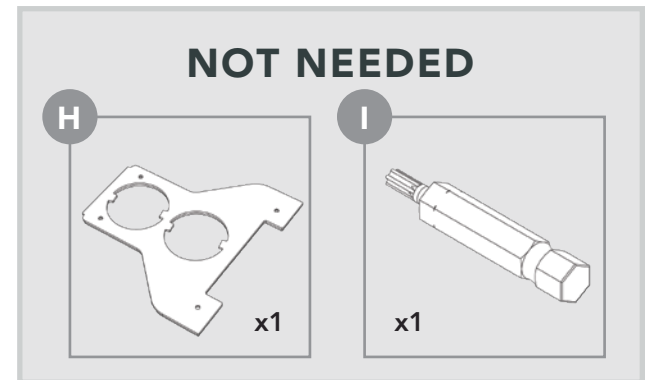
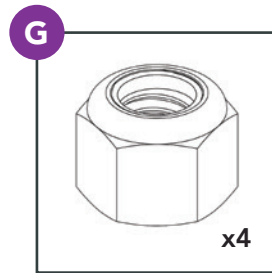
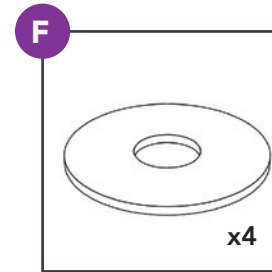
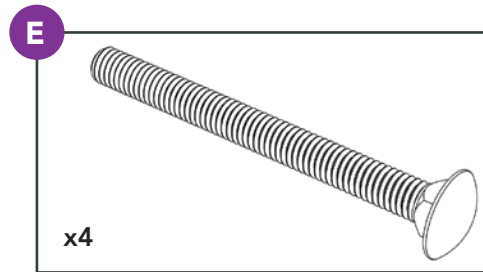
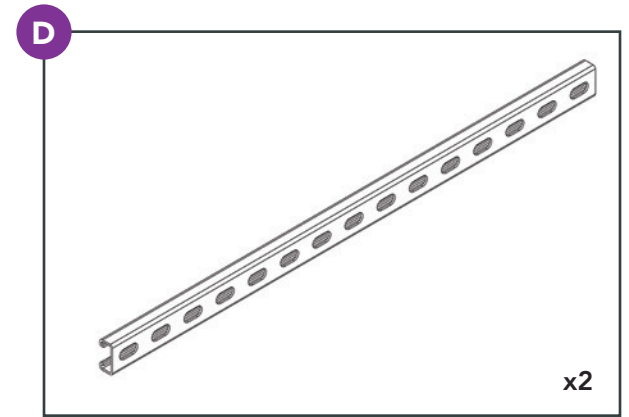
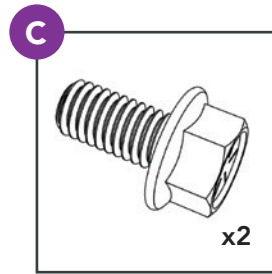
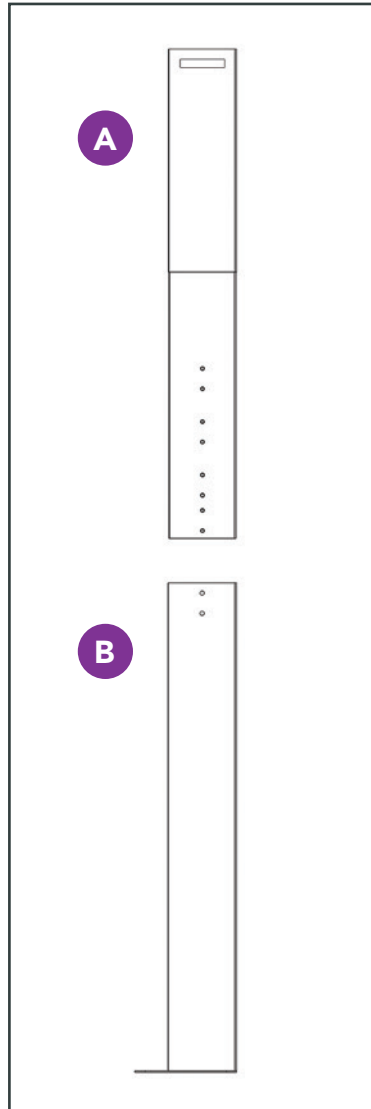

ADJUSTABLE MOUNTING POST INSTALLATION

Attaching the Vertical Posts

PREPARATION: Install the Adjustable Mounting Post separately. Please refer to the Adjustable Mounting Post Installation Guide.

When using the Adjustable Mounting Post with AisleLok Sliding Doors, the vertical posts may be mounted on either the wide or narrow side of the Adjustable Mounting Post.

AMP.1 - Slightly angle the Vertical Post and place the bottom of the post up against the bottom edge of the Adjustable Mounting Post. Pivot the Vertical Post up against the side of the Adjustable Mounting Post, align the Vertical Post with the edge of the Adjustable Mounting Post. (Figure 1)

AMP.2 - Lock each of the magnets on top of the Vertical Post by turning the knobs clockwise to the lock position. (Figure 2)

AMP.3 - Attach the Anti-shear Plates to the side of the Vertical Post. Anti-shear Plates should align with the front edge of the Adjustable Mounting Post. (Figure 3)

AMP.4 - Repeat the same process for the remaining Vertical Post, on either a cabinet frame or another adjustable mounting post.

Fig.1

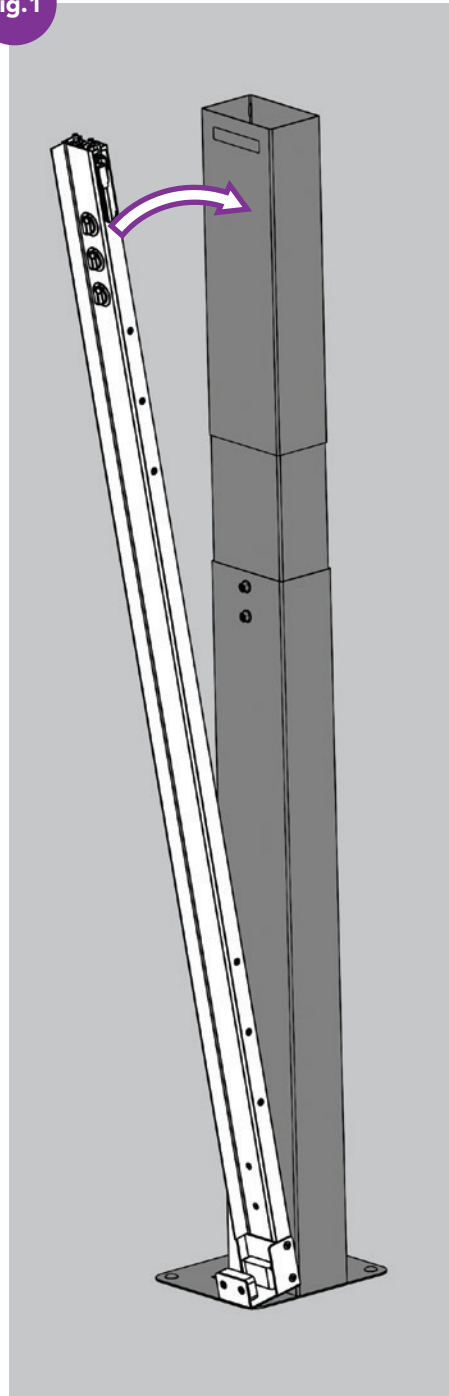

Fig.2

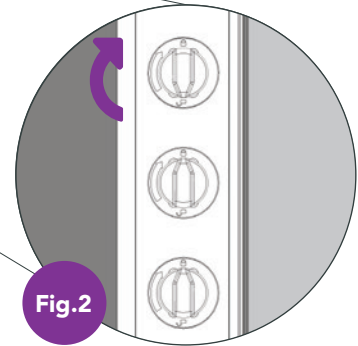
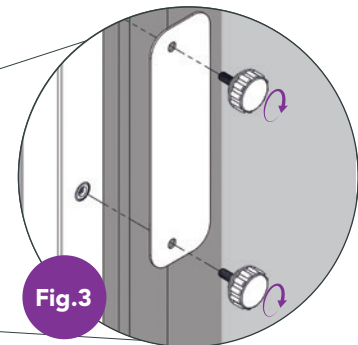

Fig.3



ADJUSTABLE MOUNTING POST INSTALLATION

Attaching the Tether Cable to the Adjustable Mounting Post

AMP.5 - Place a Thumb Screw through the eyelet at the end of the Tether Cable through the Header End Cap and into the end of the Header Assembly. **Do not fully tighten the Thumb Screw at this point.* (Figure 4)

AMP.6 - Run the end of the Tether Cable into the top of the adjustable mounting post and loop it through one of the D-Rings that are on the inside of the top post assembly. (Figure 5)

AMP.7 - Once the Tether Cable is looped through the D-Ring, push the end of the Tether Cable through the Cable Lock in the opposite direction, and pull to remove all slack. (Figure 6)

AMP.8 - Tighten the Thumb Screw to secure the Tether and Header End Cap and repeat on the opposite end of the Header Assembly.

Please go to Step 4 on page 10 to continue Sliding Door Installation.

Fig.4

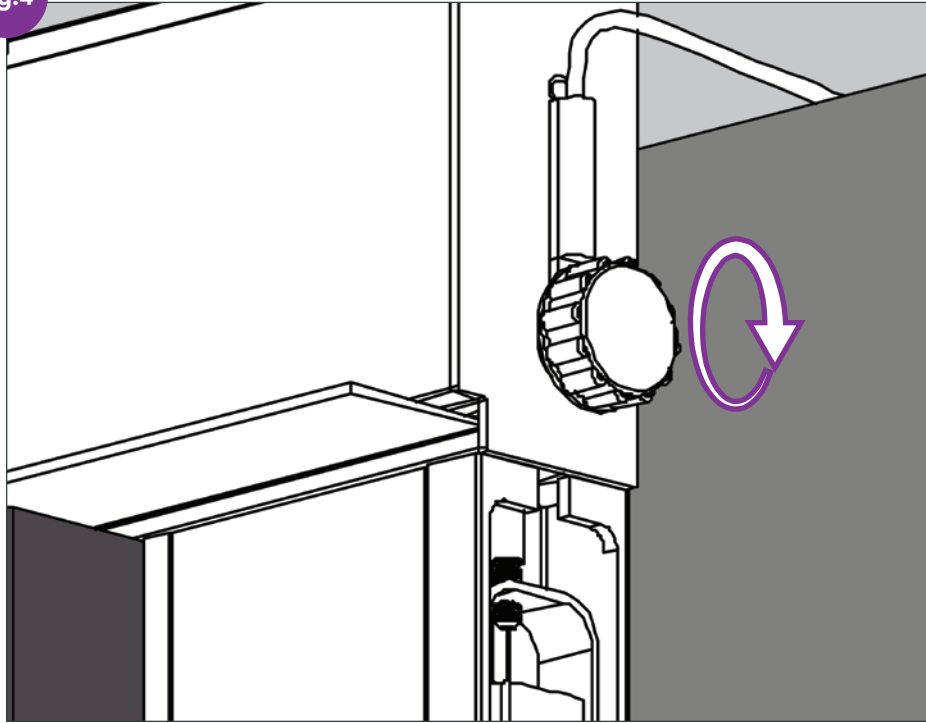

Fig.5

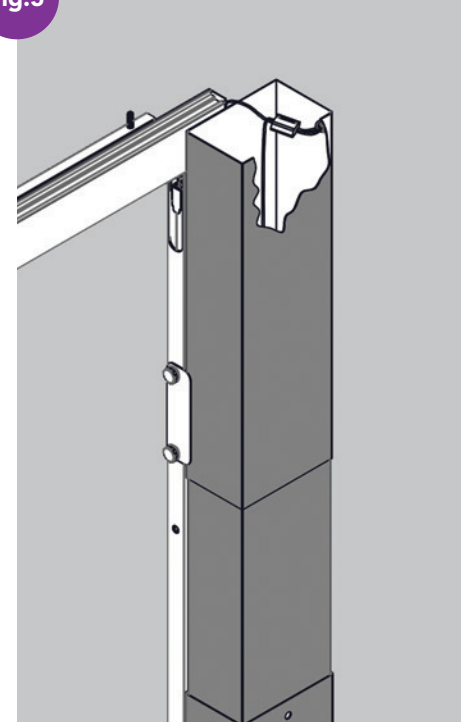
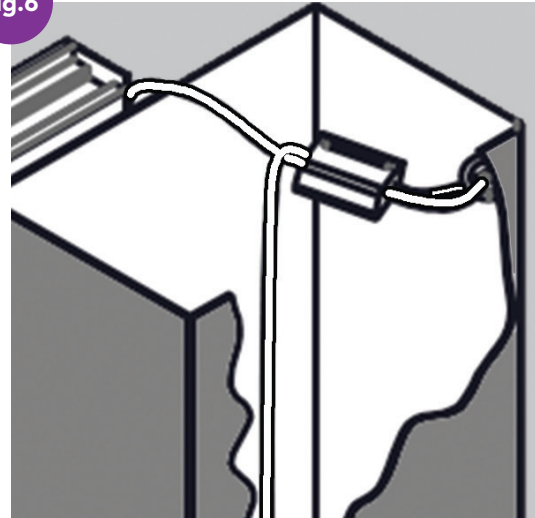

Fig.6



For Sales and Installation, contact:

 Data Clean®

(800) 328-2256 • www.dataclean.com

For Sales and Installation, contact:



(800) 328-2256 • www.dataclean.com



SLIDING DOORS

AISLELOK[®]

MECHANICAL INSTALLATION

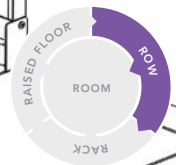

MECHANICAL INSTALLATION TIPS

The Sliding Door's Vertical Posts may need to be mechanically fastened to cabinets for some of the following reasons:

- Magnets do not sufficiently adhere to cabinets with side panels that cover the frame
- Magnets do not adhere to cabinets with aluminum frames
- Magnets do not sufficiently adhere to cabinets with thin sheet metal frames
- Mechanical attachment is preferred/required

For Sales and Installation, contact:



(800) 328-2256 • www.dataclean.com

MECHANICAL INSTALLATION

Mechanical Installation of Sliding Doors

NOTE: Hardware not included! Max drill bit size: Ø .201" [5mm]

MI.1 - Determine where on the cabinet you are going to place the Vertical Post. (Figure 1)

MI.2 - Locate the two guides which are slight indentations that run vertically on the Vertical Post. Guides are located to insure the inner structural members will be missed when drilling and screwing through the Vertical Posts. (Figure 2)

MI.3 - Slightly angle the Vertical Post and place the bottom of the post up against the bottom edge of the cabinet frame. Pivot the Vertical Post up against the side of the cabinet. (Figure 3)

MI.4 - Once the hardware locations on the Vertical Post and cabinet are determined, remove the Vertical Post from the server room and drill the necessary through holes. Make sure to remove all shavings and or debris before Vertical Posts are returned to the server room. (Figure 4)

Mechanical Installation continued on the next page.

For Sales and Installation, contact:



(800) 328-2256 • www.dataclean.com

Fig.1

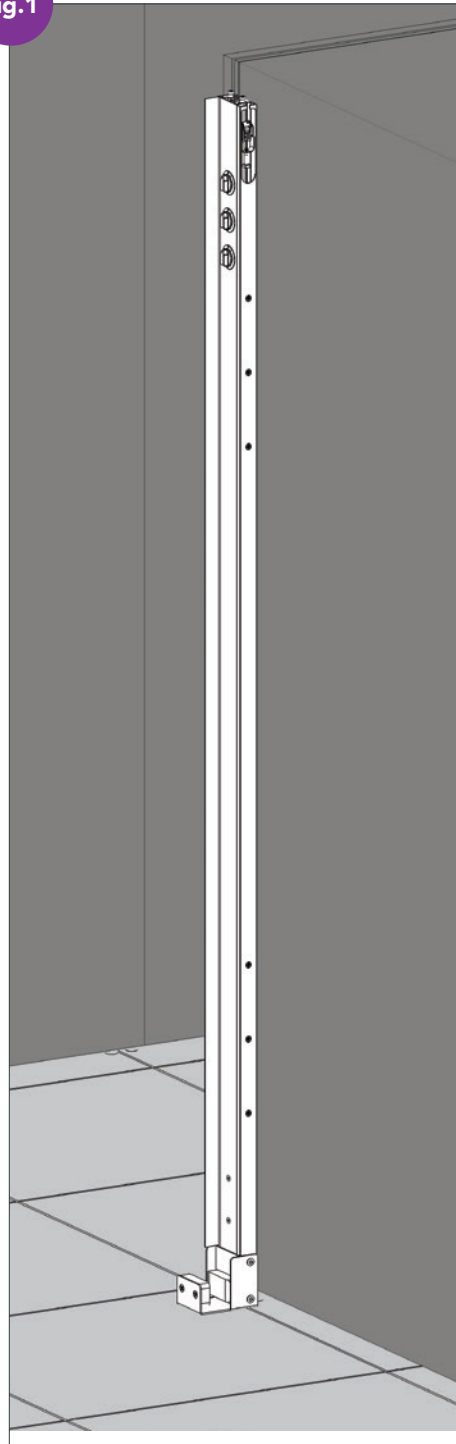

Fig.2

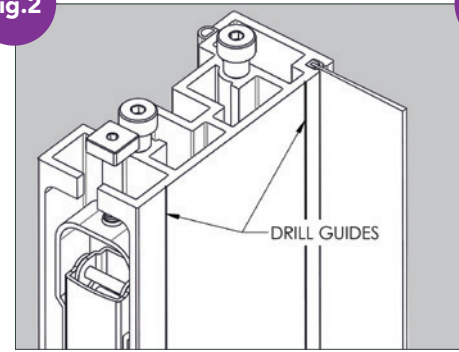
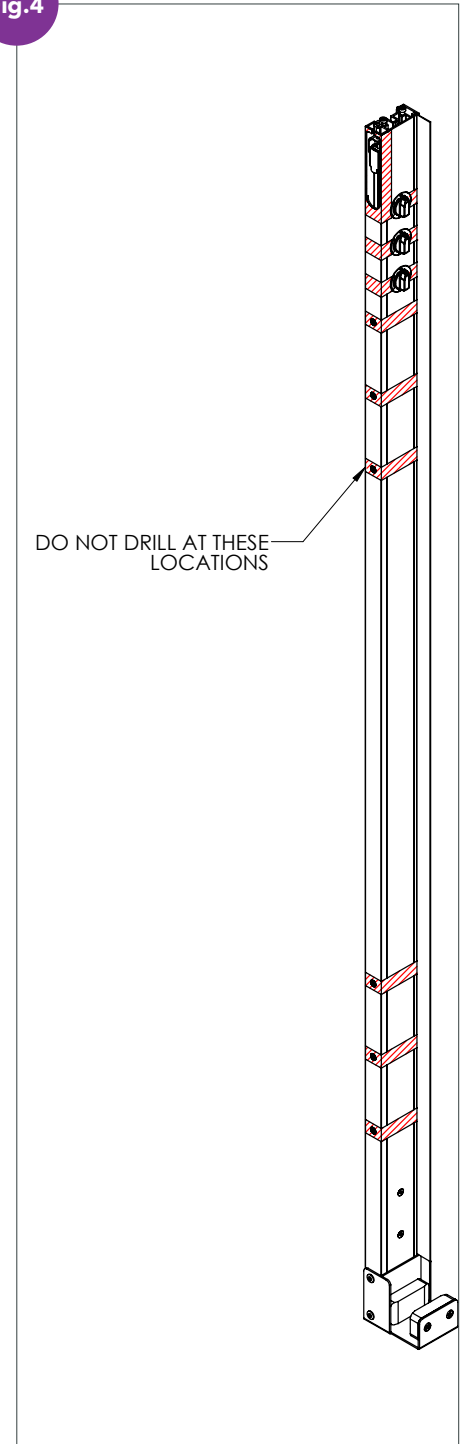

Fig.3



Fig.4



MECHANICAL INSTALLATION

Mechanical Installation of Sliding Doors

Fig.5

MI.5 - Slightly angle the Vertical Post and place the bottom of the post up against the bottom edge of the cabinet frame. Pivot the Vertical Post up against the side of the cabinet. Align the Vertical Post with the determined hardware locations on the cabinet. (Figure 5)

MI.6 - Use hardware to attach the Vertical Post to the cabinet.

MI.7 - If being placed on ferrous metal, lock each of the magnets on top of the vertical post by turning the knobs clockwise to the lock position. (Figure 6)

MI.8 - Repeat the same process for the remaining Vertical Post.

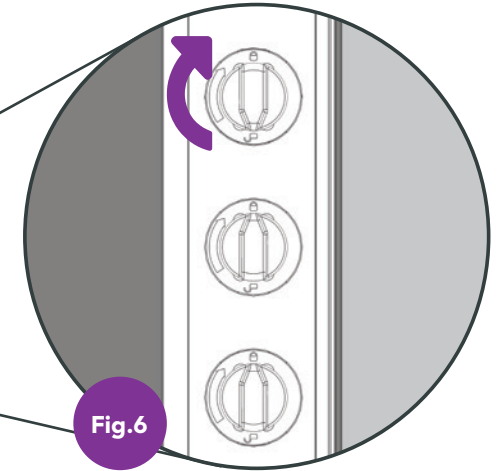
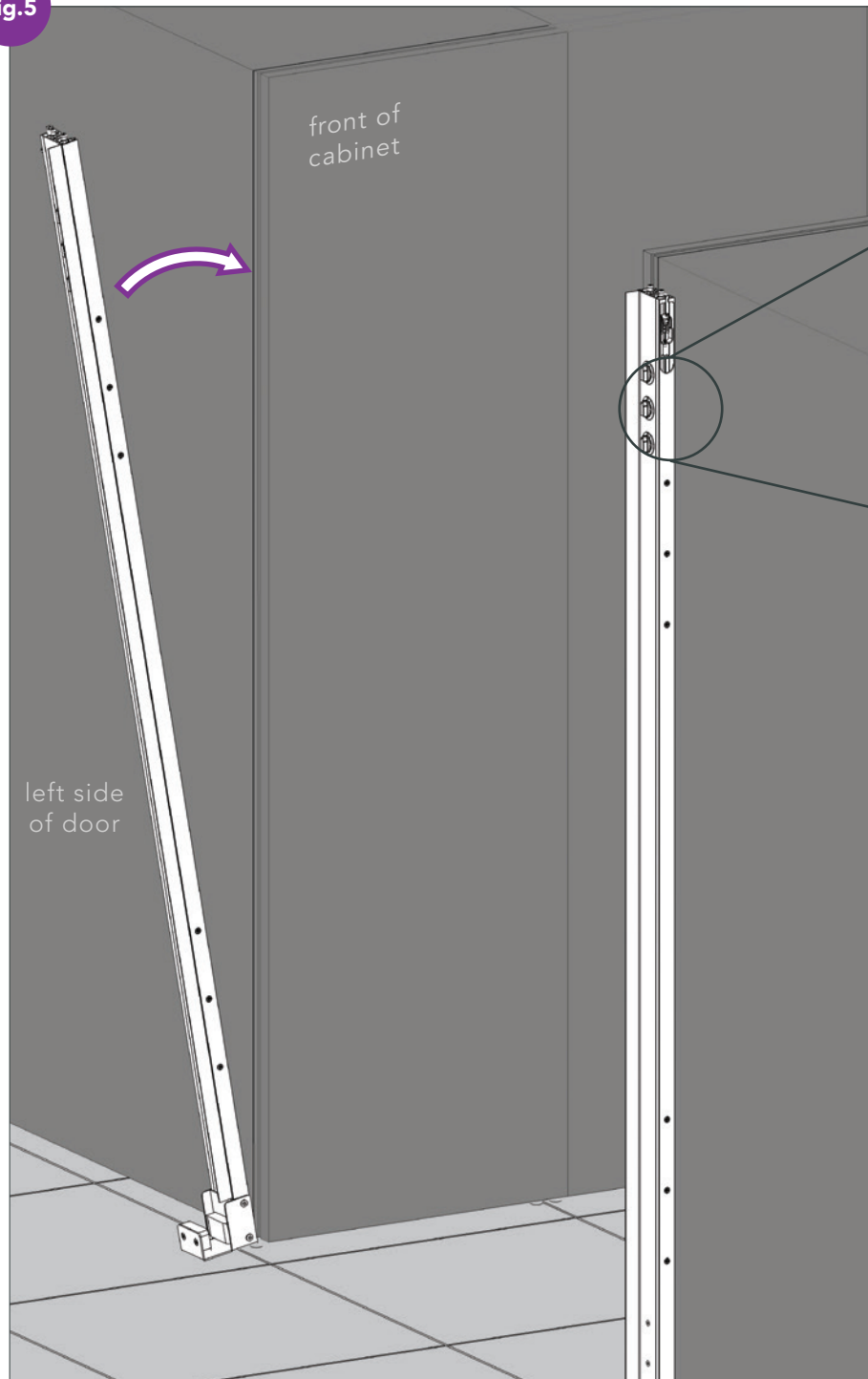

Fig.6

For Sales and Installation, contact:

Data Clean[®]

(800) 328-2256 • www.dataclean.com

INSTALLATION TIPS

General Installation

While it is possible for a single person to install the Sliding Doors, we recommend a two person installation team. To get a better understanding of the installation process please view of Installation Overview and Timed Installation videos locate on the Sliding Doors page of the Upsite Technologies website.

Door Alignment

- **There are three types of Sliding Door alignment considerations:** first is aligning the seam between the doors where they meet, the second is aligning the face of the doors, and the third is aligning the height of the doors.
- **Seam Between Doors** - Alignment of the seam between the doors is achieved by placing spacers under the door hanger bracket as described in the installation instructions. (See page 9, Step 4.4, Fig. 4)
- **Door Height** - In some cases, even with the doors meeting parallel, the doors may hang at different heights. In these cases, additional Sliding Door Shims can be placed under the hanger bracket on both sides of the lower door to raise it to the height of the other door.
- **Placing Sliding Door Shims on Studs** – When placing shims on the studs attached to door slides it is not necessary to fully remove the doors. First be sure that the thumb screws have been removed, and then lift up one side of the door, pivoting the door on the other post. While one person holds the door up another person can place shims on the desired stud. When shims have been placed, the door can be lowered down and the studs will align with the holes in the hanger bracket. This is much simpler than removing the door completely.
- **Faces of Doors Not Flush** - This is due to the cabinets not being parallel / plumb. The tops of the doors will always be aligned because they are connected to the header. The alignment of the bottoms of the doors is dependent on how plumb the cabinets are on each side. Use a level and adjust the leveling feet until the cabinets are plumb.

Placing Door Panels on Header

When placing the door panels on the header it can be challenging to align the studs on the header with the holes in the hanger bracket attached to the door. One way to make this process easier is to place the door panels on the header an inch or two in the direction of being open, in other words away from the center line, then slide the door panels towards the center line or fully closed position. As the studs and holes lineup the door panels will slide down into place.

Tethers and Cable-locks

- To simplify the process of securing the tethers and cable locks it is useful to pre-position the cable lock on the tether. After the tether has been secured to the header with the thumb screw, determine the best final position for the cable lock. Adjust the position of the cable lock on the tether so there is no slack between the header and the cable lock. Then thread the loose end of the tether through the desired hole in the top of the cabinet or other secure location and then run the tether through the cable lock and remove all slack. (See page 7 and page 8)
- Attach the tether to the end of the header with the thumb screw before looping the tether through a secure location.

4Rs

The AisleLok Sliding Doors are an integral part of our 4Rs Methodology. Learn more about the 4Rs Methodology at our website - [upsite.com/resources/airflow-management-education/](https://www.upsite.com/resources/airflow-management-education/)

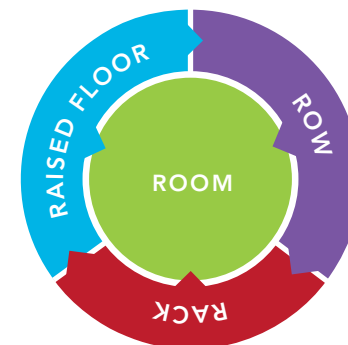

TROUBLE SHOOTING

One of the doors won't close on its own

Ensure the Header Assembly is level. If not then gravity may not be able to close the door. Level the Header Assembly by placing a Sliding Door Shim(s) under the base of the Vertical Post.

Please note: the Sliding Doors have are designed with a "hold open" feature when the doors are fully opened. This is to allow for ease of access with carts or other tools/items.

The doors come together but the door edge seals interfere with each other and prevent the doors from closing fully.

This is likely due to the cabinets not being plumb. (See "**Faces of Doors Not Flush**" on page 23 for instructions on plumbing the cabinets.)

Tether Cable lock is stuck

The Tether Cable locks can become tightly fixed to the cable, particularly if the doors have been knocked off the cabinets and the Tether Cables have caught their weight. To help free a Tether Cable lock when trying to loosen the Tether Cable, first push the Tether Cable into the cable lock in the opposite direction you are trying to move it, the direction indicated by the arrow on the side of the lock. Then it will be much easier to use the release tab on the lock to allow the Tether Cable to slide through the lock.

For Sales and Installation, contact:



(800) 328-2256 • www.dataclean.com

LIMITED WARRANTY

Upsite Technologies, Inc. (the Company) warrants to the original purchaser that products delivered hereunder will be free of defects in materials and workmanship for a period of twelve (12) months from the date of purchase (the "Warranty Period").

The Company shall, at its option, within the Warranty Period, either repair or replace free of charge, any product or part thereof found, upon the Company's inspection, to be defective in materials and workmanship, and will return the repaired or replaced product to the purchaser at Company's expense.

For warranty service and shipping instructions, contact the Company at the telephone number shown below. If the product is under warranty and the defect appears to be covered by this Limited Warranty, the Company will issue to the purchaser a Notice of Authorization For Warranty Return. Products returned to the Company for warranty service must be accompanied by a statement of defect, the Notice of Authorization for Warranty Return provided by the Company, and proof of purchase.

This Limited Warranty is conditioned on the following:

The Company must be notified within 12 months of purchase and have been given the opportunity of inspection by return of any alleged defective product free and clear of all liens and encumbrances to the Company or its manufacturer; and

The product must not have been abused, misused, or improperly maintained, and/or non-Upsite authorized repair performed during such period; and

Such defect has not been caused by corrosion or exposure to other than ordinary wear and tear; and

The installation and use of the product has been in accordance with the manufacturer's instructions and not been modified or customized to include but not limited to cut, resized, burned, glued, bent, re-shaped, disassembled, attachments added to, improperly installed or used in a manner other than intended.

The company makes no other express or implied warranty or representation of any kind whatsoever including any warranty of merchantability or fitness for a particular purpose and all such other warranties are hereby included.

The Company's maximum liability hereunder is limited to the purchase price of the product. In no event shall the Company be liable for any consequential, indirect, incidental, or special damages of any nature arising from the sale or use of the product, whether based in contract, tort, strict liability, or otherwise.

Note: Some jurisdictions do not allow limitations on incidental or consequential damages or how long an implied warranty lasts, so that the above limitations may not fully apply. This warranty gives specific legal rights and you may also have other rights which may vary from jurisdiction to jurisdiction.

For complete warranty and repair information Call (888) 982-7800 or visit upsite.com

U.S. and International Patents Pending

For Sales and Installation, contact:



(800) 328-2256 • www.dataclean.com