

# KOLDLOK<sup>®</sup>

## Installation Guide

### Surface Mount Raised Floor Grommet

Part Numbers:

Original - 2020

Large - 2030

XLarge - 2040

For Sales and Installation, contact:



(800) 328-2256 • [www.dataclean.com](http://www.dataclean.com)



Original 2020



Large 2030



XLarge 2040

#### Original Carton Contains

Original Grommets (10)  
Adhesive Mounting Kit (10)  
Edge-Mount Foam Strips, 10 Piece Pad (1)  
Installation Guide (1)

#### Large Carton Contains

Original Grommets (10)  
Metal Extension Long (10)  
Metal Extension Short (10)  
Adhesive Mounting Kit (10)  
Edge-Mount Foam Strips, 10 Piece Pad (1)  
Installation Guide (1)

#### XLarge Carton Contains

Original Grommets (10)  
Metal Extension Long (20)  
Adhesive Mounting Kit (10)  
Edge-Mount Foam Strips, 10 Piece Pad (1)  
Installation Guide (1)

#### Tools needed:

- Cutting tool (per floor tile manufacturer recommendations)
- Tape measure
- Isopropyl alcohol or equivalent for cleaning

#### Preparation:

##### Cutting Raised Floor Tiles

Each raised floor tile manufacturer provides instructions to properly and safely modify their products. Installers must be familiar with and observe tile manufacturer's recommendations with regard to applicable tools, cutting procedures, the design load capacity of the cut tile, and any additional underfloor supports requirements for cut raised floor tiles.

**\*IMPORTANT:** Data center best practices indicate that tiles should not be cut within the raised floor environment in order to protect equipment from harmful particulates. However, quick clean up of any debris or loose particulates is always recommended.

Clean the tile and bottom surface of the grommet using an alcohol wipe or a clean cotton cloth, damp with a solution of at least 50 percent isopropyl alcohol.

**HELPFUL TIP:** When choosing your cleaning cloth, do not use fabric or paper that will disintegrate or leave particles that could interfere with the adhesive or contribute to airborne contamination.



Designer & Manufacturer  
(888) 982-7800 [www.upsite.com](http://www.upsite.com)

# Installation Guide

## Surface Mount Raised Floor Grommets

### General Information

Dimensions and Tile Cutting Requirements	Inches (W x D x H)	Millimeters (W x D x H)
<b>Part No. 2020 Original - Overall size</b>	11" x 8 1/4" x 1 1/8"	279 x 210 x 29mm
Product height above the raised floor	1 1/4" with mounting system installed	32mm
Maximum cutout size sealed	10" x 7 1/4"	254 x 184mm
Usable cable area	33 sq in	21336 sq mm
<b>Part No. 2030 Large - Overall size</b>	12" x 11 3/4" x 1 5/16"	305 x 298 x 33mm
Product height above the raised floor	1 7/16" with mounting system installed	37mm
Maximum cutout size sealed	10" x 9 3/4"	254 x 248mm
Usable cable area	33 sq in	21336 sq mm
<b>Part No. 2040 XLarge - Overall size</b>	12" x 15" x 1 5/16"	305 x 381 x 33mm
Product height above the raised floor	1 7/16" with mounting system installed	37mm
Maximum cutout size sealed	10" x 13"	254 x 330mm
Usable cable area	33 sq in	21336 sq mm

### SAFETY REQUIREMENTS

Installers must be familiar with standard safety and risk management practices when working in raised-floor environments and when modifying floor tiles.

### Effective Installation of Cables

In order to minimize any air loss from the rack hole selection, make sure to allow for adequate slack in the cables. If the cables are under too much tension, the grommet may be pulled apart, resulting in a gap that will cause an increase in the flow of air escaping through the rack.

### Maintaining Proper Cooling of Equipment

Failure to follow computer manufacturer's guidelines for maintaining proper cooling may result in the overheating of equipment. Before sealing cable cutouts, ensure that there is adequate airflow to the intake sides of computer equipment or cabinets through devices such as perforated floor tiles or grates. Achieving proper airflow to the intake side of the computer equipment and/or cabinets is the responsibility of the customer.

# Installation Guide

## Surface Mount Raised Floor Grommets

### Product Components

#### 1. Original:

- a. One (1) KoldLok Surface Mount Raised Floor Grommet
- b. One (1) Single-sided foam pad with green stripe
- c. One (1) Double-sided foam pad with red stripe
- d. One (1) Foam strip with adhesive backing (for use in Edge Mount Installations only)

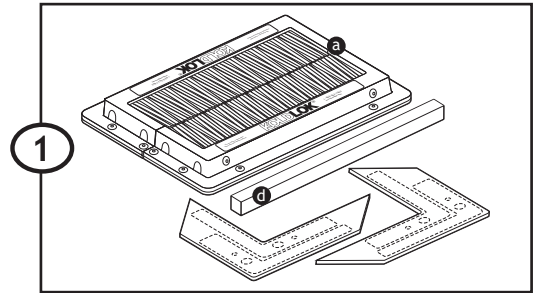

#### 2. Large:

- a. One (1) KoldLok Surface Mount Raised Floor Grommet
- b. One (1) adhesive strip for (optional) edge mount installation
- c. One (1) KoldLok Surface L Plate
- d. One (1) KoldLok Surface XL Plate
- e. Four (4) double-sided adhesive strips with red stripe
- f. Four (4) single-sided adhesive strips with green stripe
- g. Two (2) sets of double-sided adhesive gaskets with red stripe

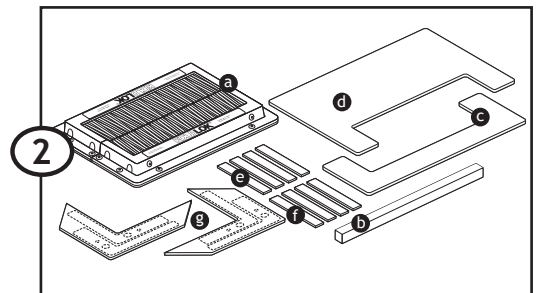

#### 3. XLarge:

- a. One (1) KoldLok Surface Mount Raised Floor Grommet
- b. One (1) adhesive strip for (optional) edge mount installation
- c. Two (2) KoldLok Surface XL Plates
- d. Four (4) double-sided adhesive strips with red stripe
- e. Four (4) single-sided adhesive strips with green stripe
- f. Two (2) sets of double-sided adhesive gaskets with red stripe

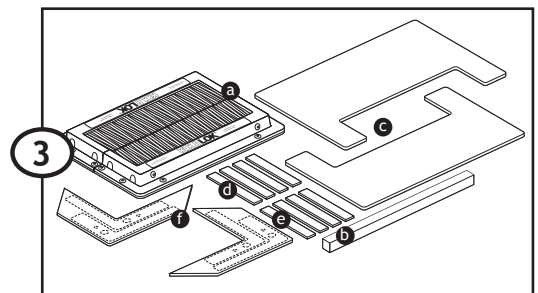

# Installation Guide

## Original Surface Mount Grommet

### Attaching Large or XLarge Extensions to the Original Surface Mount Grommet

1. Remove adhesive backing from double sided foam angles and attach to both sections of the KoldLok Surface Mount Grommet.
2. Align one side of the KoldLok Surface L or XL plate with the front edge of the Grommet section. Press to affix KoldLok Surface L or XL to the Grommet.
3. Remove adhesive backing from second section of the Grommet. Align the second side of the KoldLok Surface L or XL plate with the front edge of the second Grommet section. Press to affix KoldLok Surface L or XL plate to the Grommet.

### Attaching One Sided Adhesive to the Movable Grommet Section

4. Attach short edge adhesive strips first and trim at plate edge. Then attach the long edge strip attempting to leave no gaps between adhesive strips for best sealing. Do not remove adhesive strip backing.

### Attaching Two Sided Adhesive to the Stationary Grommet Section

5. Using 2-sided (red striped backing) adhesive gaskets and strips, carefully repeat Step 4 above.

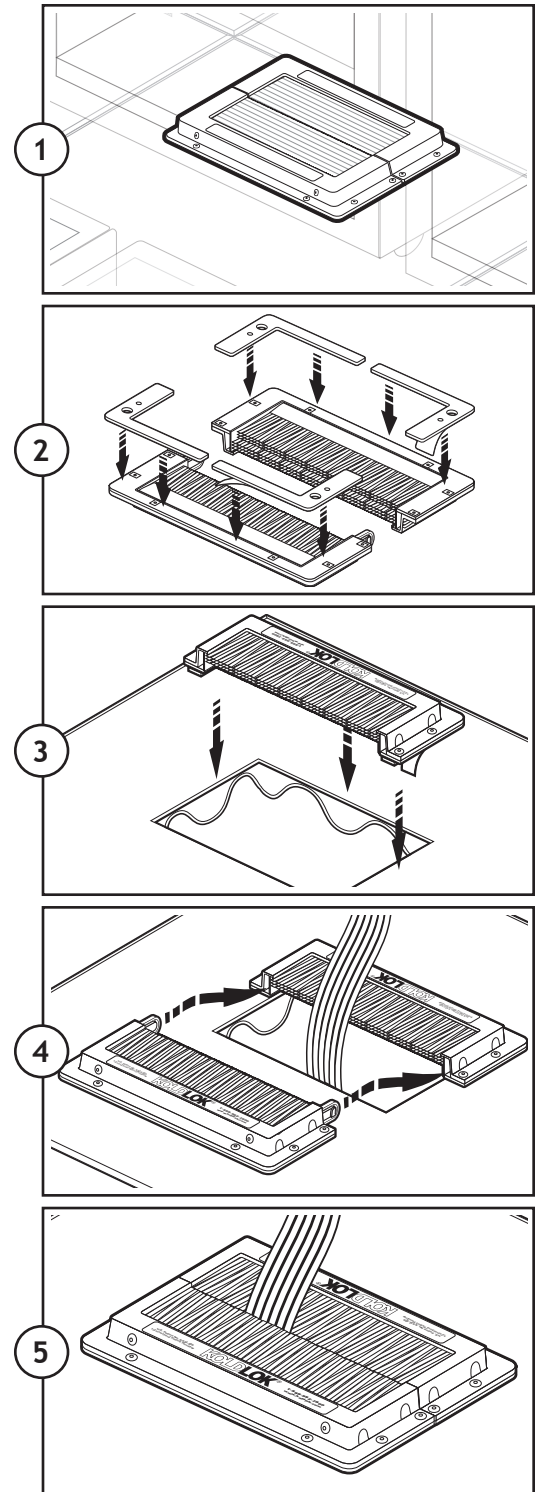

# Installation Guide

## Large & XLarge Surface Mount Grommets

### Attaching Large or XLarge Extensions to the Original Surface Mount Grommet

1. Remove adhesive backing from double sided foam angles and attach to both sections of the KoldLok Surface Mount Grommet.
2. Align one side of the KoldLok Surface L or XL plate with the front edge of the Grommet section. Press to affix KoldLok Surface L or XL to the Grommet.
3. Remove adhesive backing from second section of the Grommet. Align the second side of the KoldLok Surface L or XL plate with the front edge of the second Grommet section. Press to affix KoldLok Surface L or XL plate to the Grommet.

### Attaching One Sided Adhesive to the Movable Grommet Section

4. Attach short edge adhesive strips first and trim at plate edge. Then attach the long edge strip attempting to leave no gaps between adhesive strips for best sealing. do not remove adhesive strip backing.

### Attaching Two Sided Adhesive to the Stationary Grommet Section

5. Using 2-sided (red striped backing) adhesive gaskets and strips, carefully repeat Step 4 above.

### Attaching Stationary Section to the Floor and Assembling Grommet Around Cable Bundle

6. Assemble unit to test positioning over hole. Mark corners with pencil. Separate unit at joiner bars.
7. Remove backing from stationary section. Align stationary section with pencil marks on the floor. Place stationary section on the floor, back edges first. Adhere to floor by applying solid, downward pressure on all surfaces.
8. Re-assemble unit around cable by snapping joiner bars into place.

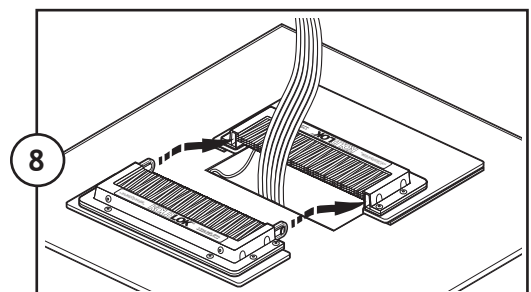
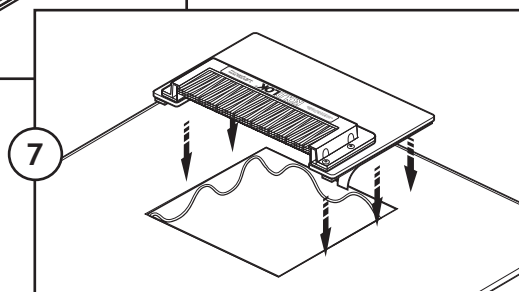
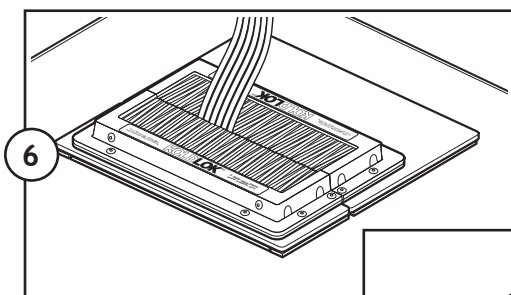
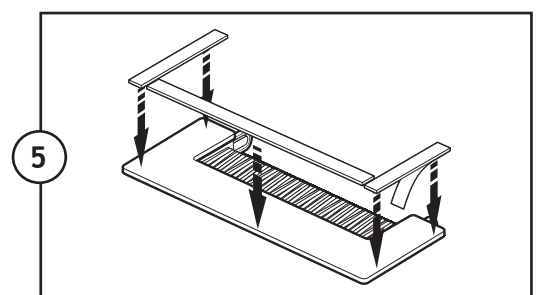
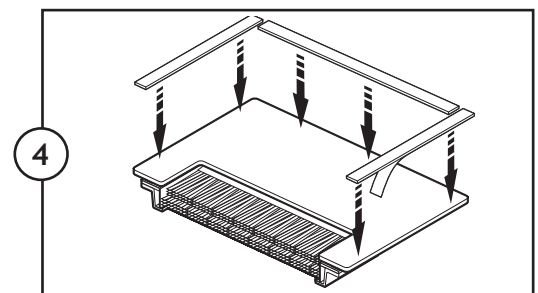
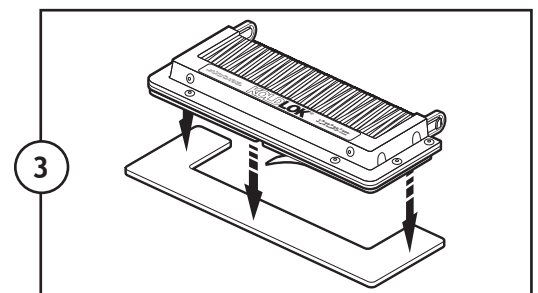
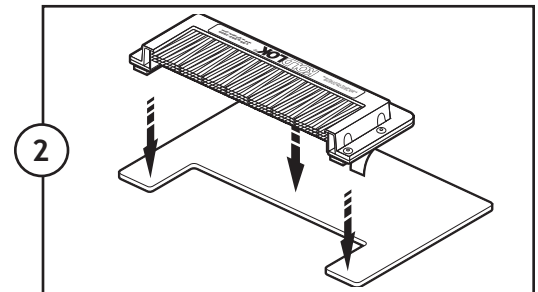
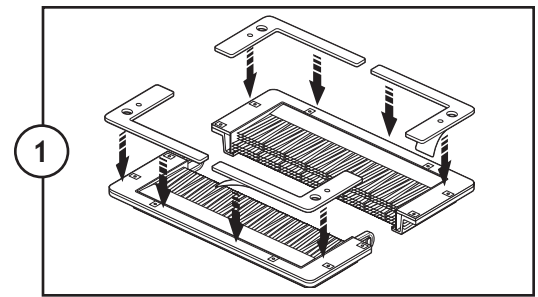

# Installation Guide

## Working With Tile

### Easy removal of movable grommet side

The movable side of the KoldLok Surface Mount Grommet is designed to be easily removed. Simply by lifting the grommet edge the joiner bar, clips will disengage from the stationary frame to allow easy one handed removal when placed under or adjacent to equipment racks.

### Installation on the Tile Edge

If the cable cutout is an edge cut and the installation of the Grommet will fall within the perimeter of the tile, the foam strip included in the gasket set must be used.

1. Apply the foam strip to the exposed stringer on the cut side of the tile to provide an air block between the stringer and the bottom of the Grommet.
2. Remove adhesive backing strips from both foam strip and grommet angle strips and adhere to floor by applying solid, downward pressure on all surfaces.
3. Final Positioning

Note: If the cable cutout is an edge cut and the Grommet will overlap onto the adjacent tile, then no foam strip is needed. If part, but not all, of the Grommet edge overlaps the trim material on the cable cutout (outside dimension of cutout trim is greater than 7 inch x 9 inch but no greater than 8 ¼ inch x 11 inch), the second layer of gaskets may be required in order to prevent air leakage.

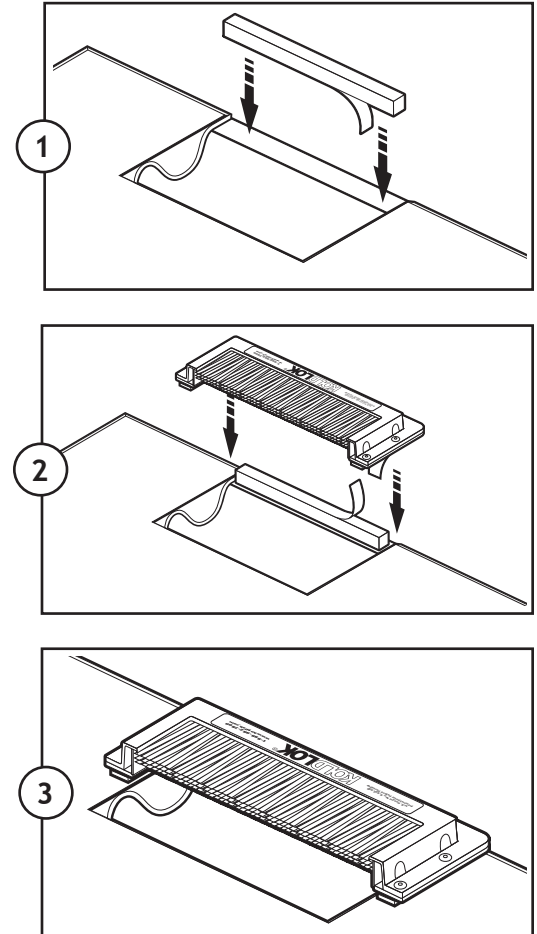

# Installation Guide

## Limited Warranty

Upsite Technologies, Inc. (the *Company*) warrants to the original purchaser that products delivered hereunder will be free of defects in materials and workmanship for a period of twelve (12) months from the date of purchase (the “Warranty Period”).

The *Company* shall, at its option, within the Warranty Period, either repair or replace free of charge, any product or part thereof found, upon the *Company’s* inspection, to be defective in materials and workmanship, and will return the repaired or replaced product to the purchaser at *Company’s* expense.

For warranty service and shipping instructions, contact the *Company* at the telephone number shown below. If the product is under warranty and the defect appears to be covered by this Limited Warranty, the *Company* will issue to the purchaser a Notice of Authorization For Warranty Return. Products returned to the *Company* for warranty service must be accompanied by a statement of defect, the Notice of Authorization for Warranty Return provided by the *Company*, and proof of purchase.

This Limited Warranty is conditioned on the following:

1. The *Company* must be notified within 12 months of purchase and have been given the opportunity of inspection by return of any alleged defective product free and clear of all liens and encumbrances to the *Company* or its manufacturer; and
2. The product must not have been abused, misused, or improperly maintained, and/or repaired during such period; and
3. Such defect has not been caused by corrosion or exposure to other than ordinary wear and tear; and
4. The installation and use of the product has been in accordance with the manufacturer’s instructions and not been modified or customized to include but not limited to cut, resized, burned, glued, bent, re-shaped, disassembled, attachments added to, improperly installed or used in a manner other than intended.

The company makes no other express or implied warranty or representation of any kind whatsoever including any warranty of merchantability or fitness for a particular purpose and all such other warranties are hereby included.

The Company’s maximum liability hereunder is limited to the purchase price of the product. In no event shall the Company be liable for any consequential, indirect, incidental, or special damages of any nature arising from the sale or use of the product, whether based in contract, tort, strict liability, or otherwise.

Note: Some jurisdictions do not allow limitations on incidental or consequential damages or how long an implied warranty lasts, so that the above limitations may not fully apply. This warranty gives specific legal rights and you may also have other rights which may vary from jurisdiction to jurisdiction.

**For complete warranty and repair information Call (888) 982-7800 or visit [upsite.com](http://upsite.com)**

U.S. Patent No. 6,632,999 and International Patents Pending